

High Pressure Fittings



TH20 SERIES

- Maximum Pressure: Up to 20,000 psi(1,380 bar)
- Size from 1/4" to 3/4" inch is available.
- Coned and Treaded connection.

ORDERING INFORMATION

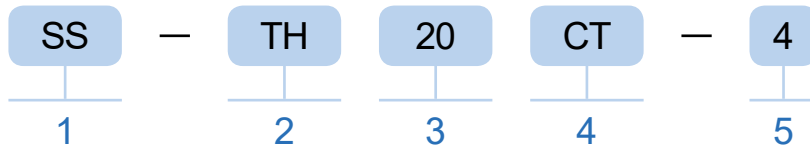

1. MATERIAL DESIGNATOR

Material	Designator
316/316L	SS

2. TKF HIGH PRESSURE FITTINGS

3. PRESSURE SERIES

Description	Designator
20,000 psi	20

4. FITTING TYPE

Description	Designator
Coupling	U
Elbow	E
Tee	T
Cross	CT
Bulkhead	BH
Cap	CP
Plug	P
Collar	C
Gland	G

5. CONNECTION SIZE

Size	Designator
1/4"	4
3/8"	6
9/16"	9
3/4"	12
1"	16

FEATURES

- One and thread connection provides dependable medium-and high-pressure performance.
- Weep holes standard on all pressure connections to verify proper connection.
- High-pressure Cone and Treaded Fittings, adapters, and couplings are supplied complete with glands and collars except where noted.
- There are 4 patterns body type. (Straight, Elbow, Tee, Cross Type)

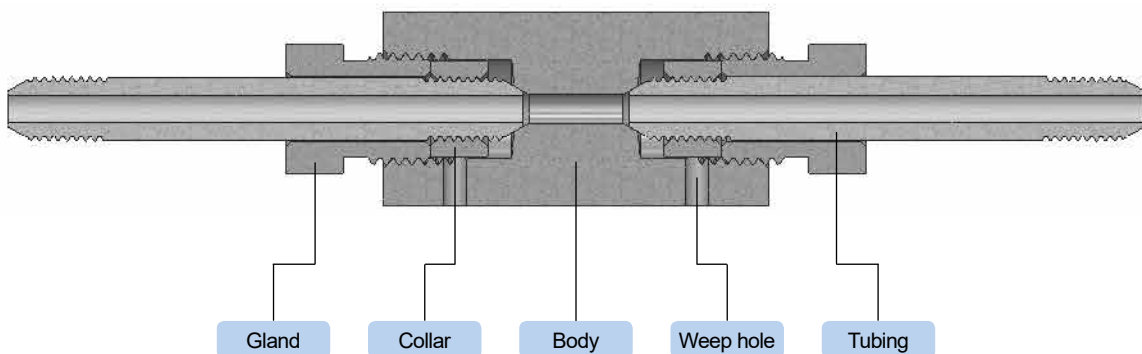

MATERIALS

316/L cold worked or high strength stainless steel standard.

Description	Component	Material
316/316L	Body	ASTMA479 316/L
	Gland	ASTMA276 316/L
	Collar	ASTMA276 316/L

PRESSURE RANGES & TEMPERATURE RANGES

Pressure Range	Temperature Range
20,000 psig (1,378 bar)	-423 °F (-252 °C) to 1200 °F (649 °C)

TEMPERATURE DERATING FACTORS

Temperature		Factors
°F	°C	
-60 to 200	-51 to 93	1.00
400	204	0.93
600	315	0.93
800	426	0.92
1,000	537	0.84

INSTALLATION INSTRUCTIONS

Step 1.

Slide the tubing into the gland.



Step 2.

Thread the collar counter-clockwise (*left-hand thread*) onto the tubing.

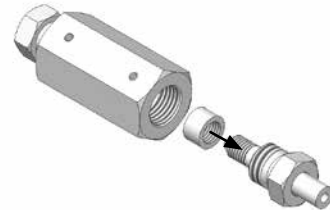

Step 3.

Continue threading until 1 to 2 full threads are exposed at the cone end of the tubing. This will indicate proper position of the collar.

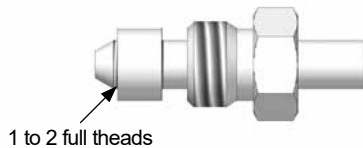

Step 4.

Insert the C&T tubing with the collar into the fitting body.

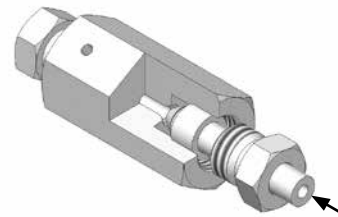

Step 5.

Make sure the cone end of the tubing rests firmly on the angled seat of the fitting body.

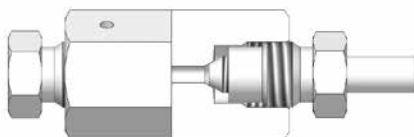

Step 6.

Thread the gland into the fitting body until finger tight. Hold the fitting body steady and tighten the gland to the required torque.

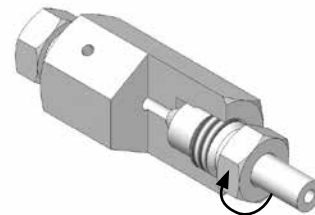

■ Required Torque

Fitting Size	Torque (N.m)
1/4"	27.2
3/8"	40.7
9/16"	74.6
3/4"	123
1"	204

DIMENSIONS

CONE & THREAD END CONNECTIONS

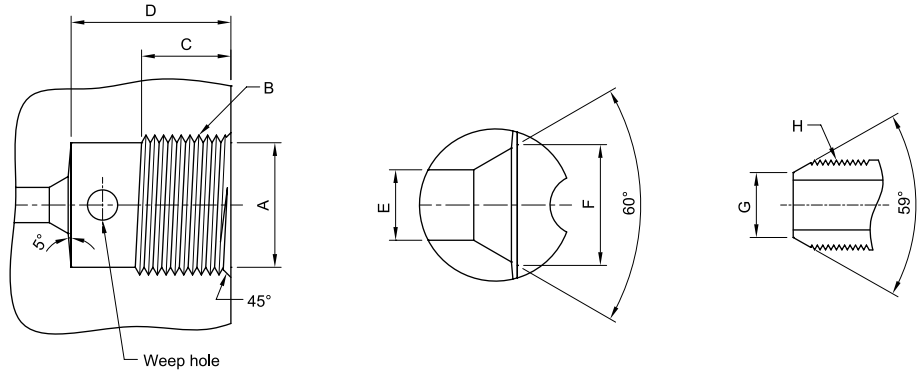

Fitting Size In.	Dimensions (mm)								Tube Engagement Length
	A	B	C	D	E	F	G	H	
1/4	9.9	7/16-20	7.1	12.7	2.8	4.6	3.6	1/4-28	14.2
3/8	13.2	9/16-18	9.7	15	5.1	9.1	6.4	3/8-24	17.5
9/16	19.0	13/16-16	11.2	19	7.9	12.7	10.4	9/16-18	21.3
3/4	24.1	3/4-14 NPSM	17.8	23.9	11.2	16.0	14.2	3/4-16	25.4

** Dimensions are for reference only and are subject to change.

COUPLING

TH20U

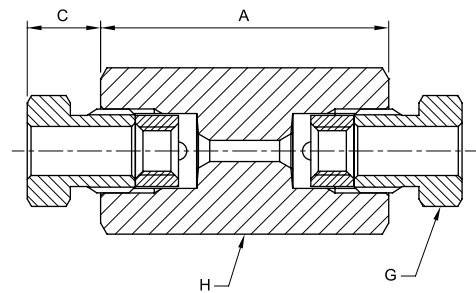
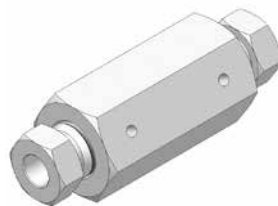

Part No.	Tube O.D. (in)	Dimensions (mm)			
		A	C	H	G
TH20U-4	1/4	38.1	9.4	3/4	1/2
TH20U-6	3/8	44.5	12.2	3/4	5/8
TH20U-9	9/16	53.8	17.3	1	7/8
TH20U-12	3/4	63.5	15.0	1 3/8	1 3/16

ELBOW

TH20E

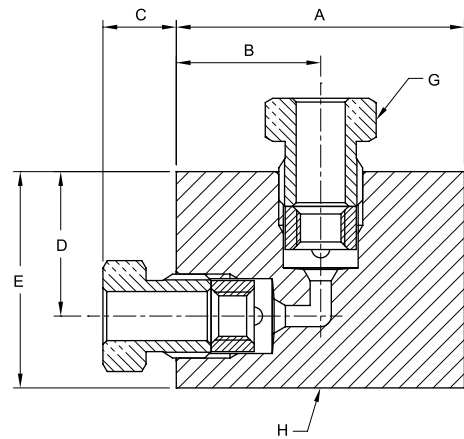
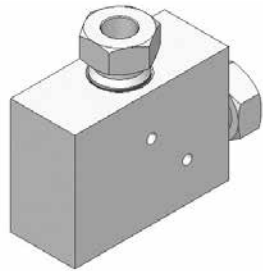

Part No.	Tube O.D. (in)	Dimensions (mm)						
		A	B	C	D	E	H	G
TH20E-4	1/4	38.1	19.1	9.7	19.1	28.6	5/8	1/2
TH20E-6	3/8	50.8	25.4	12.2	25.4	35.1	3/4	5/8
TH20E-9	9/16	63.5	31.8	17.3	31.8	44.5	1	7/8
TH20E-12	3/4	76.2	38.1	15	38.1	57.2	1 3/8	1 3/16

TEE

TH20T

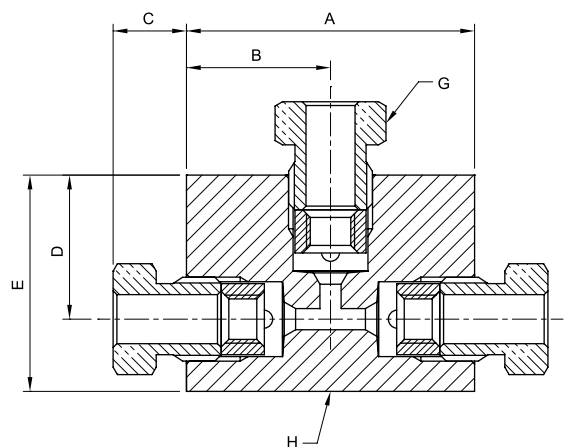
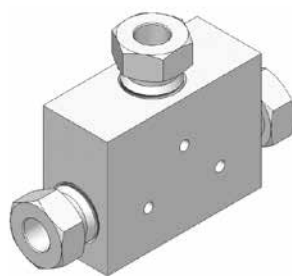

Part No.	Tube O.D. (in)	Dimensions (mm)						
		A	B	C	D	E	H	G
TH20T-4	1/4	38.1	19.1	9.7	19.1	28.6	5/8	1/2
TH20T-6	3/8	50.8	25.4	12.2	25.4	35.1	3/4	5/8
TH20T-9	9/16	63.5	31.8	17.3	31.8	44.5	1	7/8
TH20T-12	3/4	76.2	38.1	15	38.1	57.2	1 3/8	1 3/16

CROSS

TH20CT

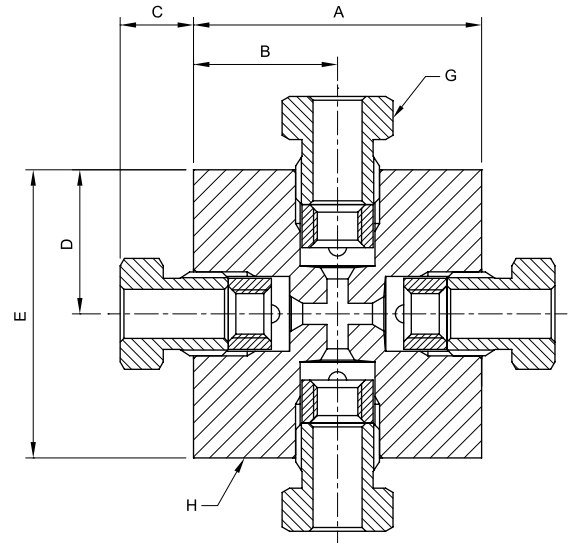
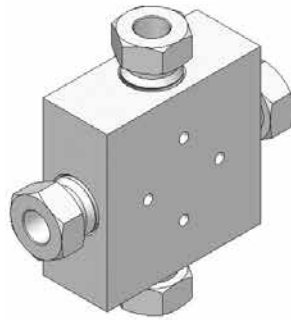

Part No.	Tube O.D. (in)	Dimensions (mm)						
		A	B	C	D	E	H	G
TH20CT-4	1/4	38.1	19.1	9.7	19.1	38.1	5/8	1/2
TH20CT-6	3/8	50.8	25.4	12.2	25.4	50.8	3/4	5/8
TH20CT-9	9/16	63.5	31.8	17.3	31.8	63.5	1	7/8
TH20CT-12	3/4	76.2	38.1	15	38.1	76.2	1 3/8	1 3/16

BULKHEAD

TH20BH

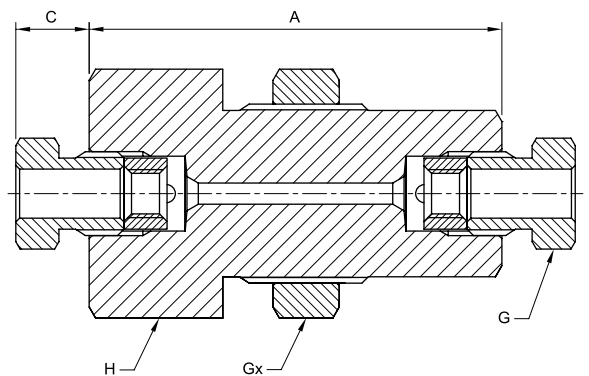
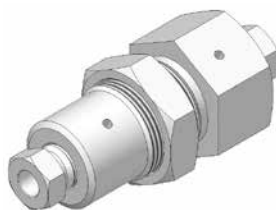

Part No.	Tube O.D. (in)	Dimensions (mm)						
		A	C	F	H	Gx	Panel Hole Size	Panel Thickness Max.
TH20BH-4	1/4	50.8	9.7	1	1/2	1	22.4	9.7
TH20BH-6	3/8	50.8	12.2	1	5/8	1	23.9	9.7
TH20BH-9	9/16	66.5	17.3	1 3/8	7/8	1 3/8	31.8	12.7
TH20BH-12	3/4	66.5	15	1 7/8	1 3/16	1 7/8	42.9	9.7

CAP TH20CP

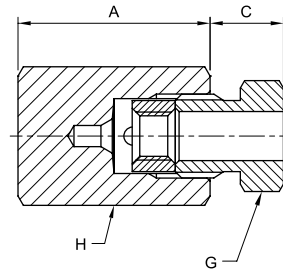
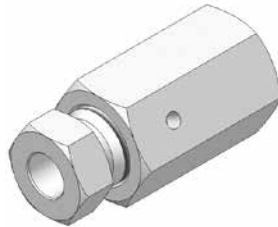

Part No.	Tube O.D. (in)	Dimensions (mm)			
		A	C	H	G
TH20CP-4	1/4	25.4	9.4	3/4	1/2
TH20CP-6	3/8	31.8	12.2	3/4	5/8
TH20CP-9	9/16	38.1	17.3	1	7/8
TH20CP-12	3/4	44.5	15.0	1 3/8	1 3/16

PLUG TH20P

TH20P

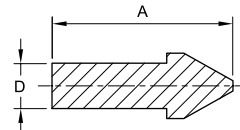

Part No.	Tube O.D. (in)	Dimensions (mm)	
		A	D
TH20P-4	1/4	25.4	6.4
TH20P-6	3/8	31.8	9.5
TH20P-9	9/16	39.6	14.2
TH20P-12	3/4	41.2	19.5

GLAND

TH20G

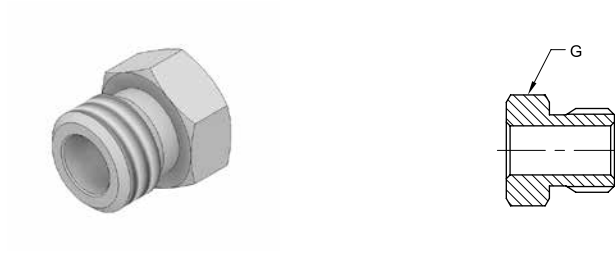

Part No.	Tube O.D. (in)	G (in)
TH20G-4	1/4	1/2
TH20G-6	3/8	5/8
TH20G-9	9/16	7/8
TH20G-12	3/4	1 3/16

COLLAR

TH20C



Part No.	Tube O.D.
TH20C-4	1/4
TH20C-6	3/8
TH20C-9	9/16
TH20C-12	3/4