

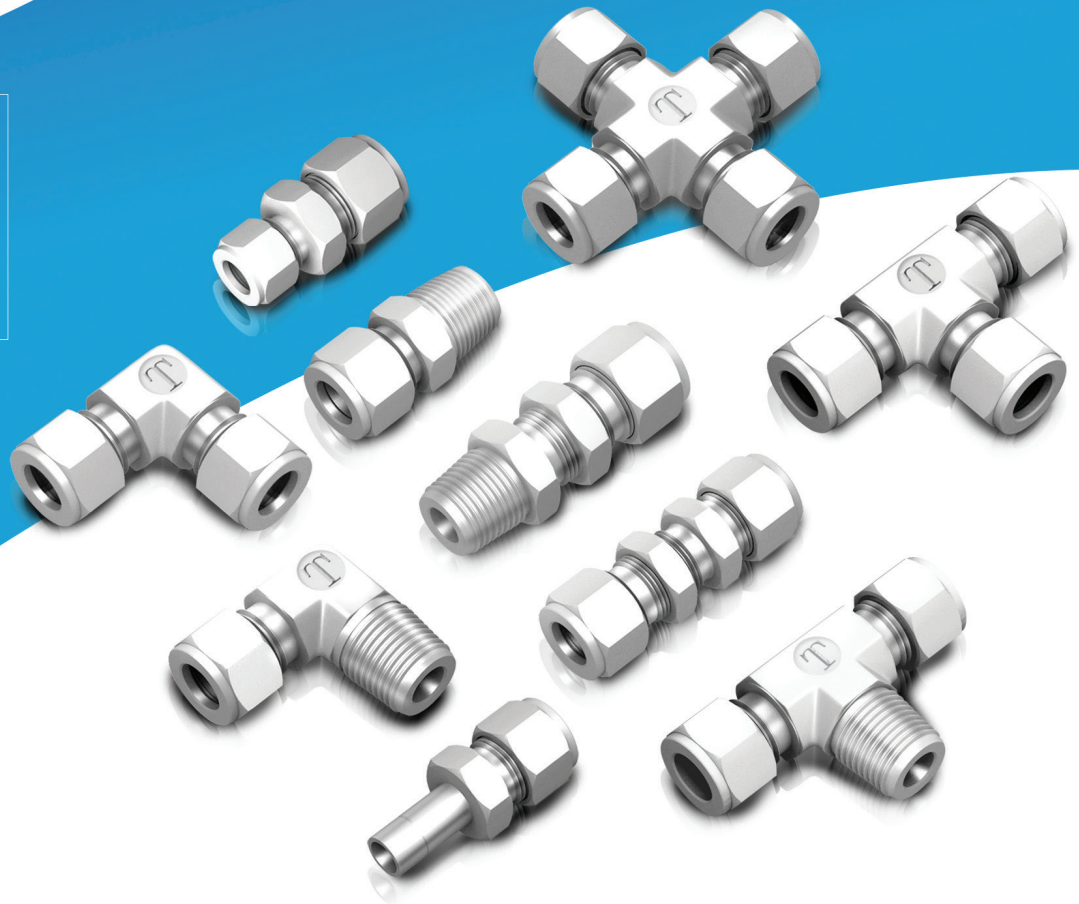









Tube Fittings



T-LOK

- Leakproof Tube Fittings
- Size from 1/16 to 2 inch and 3 to 38mm is available
- Convenient to disconnect and assemble
- Various materials and appearance

ORDERING INFORMATION	297		FEMALE 90° ELBOW 339 TFE
T-LOK INSTALLATION INSTRUCTIONS I	298		ADJUSTABLE ELBOW 341 TAE
TUBING DATA	299		MALE RUN TEE 342 TMRT
PHYSICAL DIFFERENCES AND MARKING	302		FEMALE RUN TEE 343 TFRT
T-LOK INSTALLATION INSTRUCTIONS II	303		MALE BRANCH TEE 344 TMBT
 UNION 304 TU			FEMALE BRANCH TEE 345 TFBT
 REDUCING UNION 305 TRU			BULKHEAD UNION 346 TBU
 UNION TEE 307 TUT			BULKHEAD FEMALE CONNECTOR 347 TBFC
 REDUCING UNION TEE 308 TRUT			BULKHEAD REDUCER 347 TBR
 UNION 90° ELBOW 310 TUE			BULKHEAD 348 TBMC & TBRE
 FEMALE CONNECTOR 311 TFC			UNION CROSS 349 TUC
 FEMALE CONNECTOR (GAUGE CONNECTOR) ... 316 TFC			CAP 350 TC
 REDUCER 317 TR			PLUG 351 TP
 REDUCING PORT CONNECTOR 320 TRPC			FEMALE TUBE ADAPTER 352 TFTA
 PORT CONNECTOR 321 TPC			MALE TUBE ADAPTER 355 TMTA
 MALE CONNECTOR 322 TMC-N & TMC-P & TMC-NTC			MALE 90° ELBOW 358 TME
 MALE CONNECTOR FOR BONDED WASHER SEAL ... 326 TMC-RS			MALE 45° ELBOW 359 TMHE
 MALE CONNECTOR FOR METAL GASKET SEAL ... 328 TMC-RP			MALE RUN TEE 360 TMRT
 MALE CONNECTOR 329 TMC-SR & TMC-NOR & TMC-OR			MALE BRANCH TEE 361 TMBT
 MALE PIPE WELD CONNECTOR 331 TMPWC			FERRULE 364 TBF & TFF & TFS
 TUBE SOCKET WELD CONNECTOR 332 TTSWC			NUT & NUT-FERRULE SET 365 TFN & TNFS
 WELD BULKHEAD UNION 333 TWBU			MALE NUT (INCH) 366 TMN
 MALE 90° ELBOW 334 TME			TUBE INSER 366 TTI
 MALE PIPE WELD 90° ELBOW 338 TMPWE			
 TUBE SOCKET WELD 90° 338 TTSWE			

ORDERING INFORMATION



1. MATERIAL DESIGNATOR

Material	Designator
Stainless Steel 316/316L	Blank
Brass	B

2. T-LOK TUBE FITTING

3. FITTING TYPE

Description	Designator
Union	U
Reducing Union	RU
Union Tee	UT
Reducing Union Tee	RUT
Union 90° Elbow	UE
Female Connector	FC
Reducer	R
Reducing Port Connector	RPC
Port Connector	PC
Male Connector	MC
Male Pipe Weld Connector	MPWC
Tube Socket Weld Connector	TSWC
Male 90° Elbow	ME
Male Pipe Weld 90° Elbow	MPWE
Tube Socket Weld 90° Elbow	TSWE
Female 90° Elbow	FE
Male Run Tee	MRT
Female Run Tee	FRT
Male Branch Tee	MBT
Female Branch Tee	FBT
Bulkhead Union	BU
Bulkhead Female Connector	BFC
Bulkhead Reducer	BR
Bulkhead Male Connector	BMC
Union Cross	UC
Cap	C
Plug	P
Female Tube Adapter	FTA
Male Tube Adapter	MTA
Male 45° Elbow	MHE
Back Ferrule	BF
Front Ferrule	FF
Ferrule Set	FS
Female Nut	FN
Nut-Ferrule Set	NFS
Male Nut	MN
Tube Insert	TI

4. CONNECTION SIZE

Size	Designator
1/16"	1
1/8"	2
3/16"	3
1/4"	4
5/16"	5
3/8"	6
1/2"	8
5/8"	10
3/4"	12
7/8"	14
1"	16
1 1/4"	20
1 1/2"	24
2"	32

Size	Designator
2mm	2M
3mm	3M
4mm	4M
6mm	6M
8mm	8M
10mm	10M
12mm	12M
14mm	14M
15mm	15M
16mm	16M
18mm	18M
20mm	20M
22mm	22M
25mm	25M
28mm	28M
32mm	32M
38mm	38M
42mm	42M

5. CONNECTION TYPE

Description	Designator
T-LOK	Blank
NPT	N
	NOR
ISO Tapered	P
	RS
ISO Parallel	RP
	PR
	RG
	SR
Unified Screw	OR
	ST
	TW
Male Pipe Weld	TW
Tube Socket Weld	SW
Thermocouple Connector	TC

T-LOK INSTALLATION INSTRUCTIONS

FEATURES

T-LOK is a high performance tube fitting that combines the sealing properties and quality control technologies required for power plant instrumentation fittings, other industries and the ultra-pure construction required used in fittings used in semiconductor manufacturing equipment. T-LOK is new value series that provides high performance, cost effectiveness, and quick delivery. T-LOK tube fittings combine leading edge manufacturing technology and exceptional cost performance.

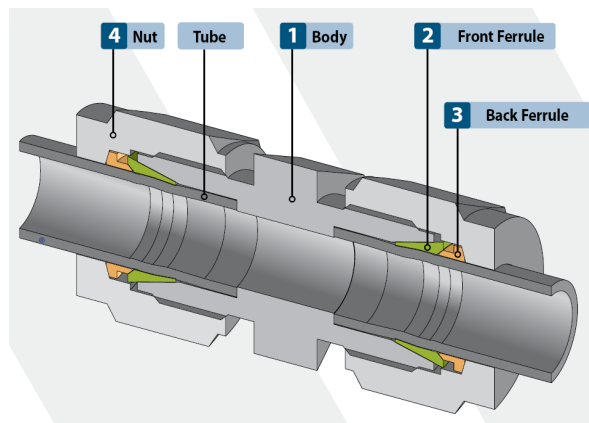

MATERIALS

Description	Bar Stock	Forgings
Stainless Steel 316 / 316L 304 / 304L	ASTM A276, ASME SA276 ASTM A479, ASME SA479	ASTM A182 ASME SA182
Brass	JIS C3604 ASTM B16 Alloy 360 ASTM B453 Alloy 345 C3601-C3604	JIS C3771BE ASTM B283 Alloy 377 ASTM B124 Alloy 377 C371-C3771

TUBING TEMPERATURE RANGES

Tubing Material	Temperature Range
Stainless Steel	-321°F to 1200°F (-196°C to 649°C)
Brass	-65°F to 400°F (-54°C to 204°C)

ALLOWABLE WORKING TEMPERATURE

When Elastomer seal is used in the fitting, care must be taken for allowable working temperature.

Elastomer seal material	Working Temperature
NBR (Perbunan®)	-40°F to 212°F (-40°C to 100°C)
FKM (Viton®)	-15°F to 450°F (-26°C~232°C)
FFKM (Kalrez®)	-22°F to 527°F (-30°C~275°C)
PTFE (Teflon®)	-65°F to 450°F (-54°C to 232°C)

INSTALLING FITTINGS NEAR TUBE BENDS

Before tightening T-LOK fittings, the end of the tube must be flush against the shoulder of the body hex. Therefore, when installing fittings near tube bends, there must be a sufficient straight length of tubing to allow for proper installation. (see the table to the left)

Fractional (INCH)		Metric (mm)	
T Tube OD	L	T Tube OD	L
1/16"	1/2	3	19
1/8"	23/32	6	21
3/16"	3/4	8	23
1/4"	13/16	10	25
5/16"	7/8	12	31
3/8"	15/16	14	32
1/2"	13/16	15	
5/8"	1 1/4	16	
3/4"		18	
7/8"	1 5/16	20	34
1"	1 1/2	22	
1 1/4"	2	25	40
1 1/2"	2 13/32	28	46
2"	3 1/4	30	50
		32	54
		38	63

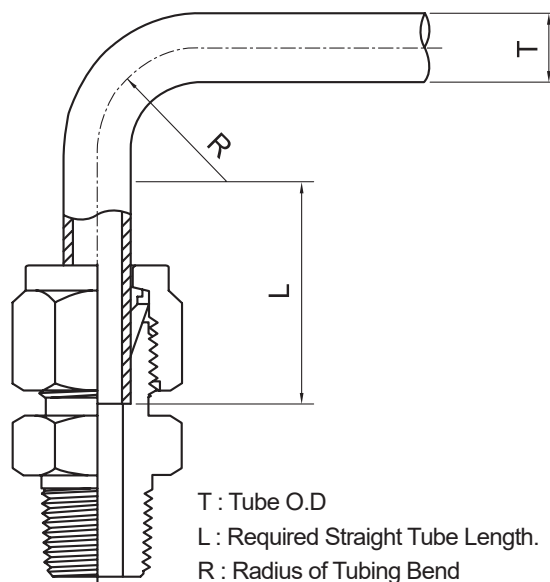

TUBING DATA FOR STAINLESS STEEL

TABLE 1: MAXIMUM ALLOWABLE WORKING PRESSURE FOR STAINLESS STEEL TUBING

- Fully Annealed seamless type 304/304L, 316/316L to ASTM A269 or equivalent
- Hardness: RB90 or less

Tube O.D. INCH	Tube Wall Thickness (INCH)															
	0.010	0.012	0.014	0.016	0.02	0.028	0.035	0.049	0.065	0.083	0.095	0.109	0.120	0.134	0.156	0.188
1/16"	5600	6800	8100	9400	12000											
1/8"						8500	10900									
3/16"						5400	7100	10200								
1/4"						4000	5100	7500	10200							
5/16"							4000	5800	8000							
3/8"							3300	4800	6500							
1/2"							2600	3750	5100	6700						
5/8"								2900	4000	5200	6000					
3/4"								2400	3300	4200	4900	5800				
7/8"								2000	2800	3600	4200	4800				
1"									2400	3100	3600	4200	4700			
1 1/4"										2400	2800	3300	3600	4100	4900	
1 1/2"											2300	2700	3000	3400	4000	4900
2"												2000	2200	2500	2900	3600

Tube O.D. mm	Tube Wall Thickness (mm)													
	0.8	1.0	1.2	1.5	1.8	2.0	2.2	2.5	2.8	3.0	3.5	4.0	4.5	
3	10400	13700												
4	7500	9700	12100											
6	4780	6230	7500	9800										
8		4490	5500	7100										
10		3480	4350	5500	6800	7680								
12		2900	3480	4490	5500	6230								
14		2610	3190	4060	4930	5650	6230							
15		2465	2900	3770	4640	5220	5800							
16			2755	3480	4350	4780	5360	6230						
18			2465	3040	3770	4200	4780	5510						
20			2175	2755	3330	3770	4200	4780	5510					
22			2030	2465	3045	3480	3770	4350	4930					
25				2175	2610	2900	3330	3770	4350	4640				
28						2610	2900	3330	3770	4060	4780			
30						2465	2755	3045	3480	3770	4490			
32						2320	2465	2900	3335	3480	4200	4780		
38							2030	2465	2755	2900	3480	4060	4490	

- According to the requirements of ASME B31.3 (Process piping Code)
- Allowable working pressures are calculated from an S value of 20,000psi for ASTM A269 Tubing (at -20 to 100°F(-28 to 37°C))
- Safety Factor: 3.75 : 1, Ultimate tensile strength of 75,000psi
- For Weld Tubing Pressure
 - ASME 31.1(Power Piping Code)
 - for double welded tubing: working pressure x 0.85
 - for single welded tubing: working pressure x 0.80
- For gas service, select a tube wall thickness outside of the shaded area.

TUBING DATA FOR COPPER

TABLE 2: MAXIMUM ALLOWABLE WORKING PRESSURE FOR COPPER TUBING

- Soft annealed seamless copper tubing, ASTM B75 or equivalent. (Temper O with Max. hardness 60)
- Seamless water tubing type K or type L to ASTM B88 (Temper O with Max. hardness 50)

Tube O.D. INCH	Tube Wall Thickness (INCH)										
	0.010	0.012	0.028	0.030	0.035	0.049	0.065	0.083	0.095	0.109	0.120
Working Pressure (psig)											
1/16"	1650	2100	6700	9800							
1/8"			2800	3000	3600						
3/16"			1800	1900	2300	3400					
1/4"			1300	1400	1600	2500	3600				
5/16"					1300	1900	2700				
3/8"					1000	1600	2200				
1/2"					800	1100	1600	2100			
5/8"						900	1200	1600	1900		
3/4"						700	1000	1300	1500	1800	
7/8"						600	800	1100	1300	1500	
1"						500	700	900	1100	1300	1500

Tube O.D. mm	Tube Wall Thickness (mm)									
	0.8	1.0	1.2	1.5	1.8	2.0	2.2	2.5	2.8	3.0
Working Pressure (psig)										
3	3300	4640								
4	2465	3190	4200							
6	1595	2030	2465	3190	4200					
8	1100	1450	1740	2320	2900					
10	900	1160	1450	1885	2300	2600				
12	750	870	1160	1450	1885	2030				
14		725	870	1305	1595	1740	1885	2300		
15			870	1160	1450	1595	1740	2100		
16				1015	1305	1450	1595	1740		
18				870	1160	1305	1450	1595	1885	2100
20				870	1015	1160	1305	1450	1595	1885
22				725	870	1015	1160	1305	1450	1740
25				580	725	870	1015	1160	1305	1450
28					580	725	870	1015	1160	1305

- According to the requirements of ASME B31.3(Process piping Code)
- Allowable working pressures are calculated from an S value of 6,000psi for ASTM B75 & B88 Tubing (at -20 to 100°F(-28 to 37°C))
- Safety Factor: 3.75 : 1, Ultimate tensile strength of 30,000psi
- For gas service, select a tube wall thickness outside of the shaded area.

TUBING DATA

TABLE 3: TEMPERATURE DERATING FACTORS

Temperature		Tubing Materials	
°F	°C	Stainless Steels	Copper
100	38	1.00	1.00
200	93	1.00	0.80
300	149	1.00	0.78
400	204	0.96	0.50
500	260	0.90	-
600	315	0.85	-
700	371	0.82	-
800	426	0.79	-
900	482	0.78	-
1000	537	0.76	-
1100	593	0.62	-
1200	649	0.37	-

- To determine allowable pressure at higher temperature, multiply allowable working pressure from Table 1, 2 by factors shown in Table 3.
- For Example
 - Stainless steel tubing 1/2" O.D. X 0.049" wall at 800°F(426°C)
 - The elevated temperature factor for 800°F(426°C) is 0.79 (3,750psig X 0.79 = 2,962psig)

TABLE 4: GAS ALLOWABLE TUBING

Stainless Steel Tubing					Copper Tubing				
Metric		Fractional			Metric		Fractional		
Tube O.D.	Min. Nominal Wall Thickness	Tube O.D.	Min. Nominal Wall Thickness		Tube O.D.	Min. Nominal Wall Thickness	Tube O.D.	Min. Nominal Wall Thickness	
	mm		INCH	mm		mm		INCH	mm
3	0.8	1/8"	0.028	0.71	8	1.0	1/8"	0.028	0.71
6	0.8	3/16"	0.028	0.71	10	1.0	3/16"	0.028	0.71
8	1.0	1/4"	0.028	0.71	12	1.0	1/4"	0.028	0.71
10	1.0	5/16"	0.035	0.89	14	1.2	5/16"	0.035	0.89
12	1.0	3/8"	0.035	0.89	16	1.2	3/8"	0.035	0.89
14	1.2	1/2"	0.049	1.24	18	1.5	1/2"	0.049	1.24
16	1.5	5/8"	0.065	1.65	20	1.8	5/8"	0.065	1.65
18	1.5	3/4"	0.065	1.65	22	2.0	3/4"	0.065	1.65
20	1.8	7/8"	0.083	2.11	25	2.2	7/8"	0.083	2.11
22	2.0	1"	0.083	2.11	28	2.5	1"	0.083	2.11
25	2.2	1 1/4"	0.109	2.77					
28	2.5	1 1/2"	0.134	3.40					
32	3.0	2"	0.188	4.78					
38	3.5								

- For Gas applications, we recommend tubing with a greater wall thickness.
- Table 4 shows the recommended min thickness.
- Wall thicknesses for greater safety and efficiency

Attention!

1. The value of Table 1, Table 2 are maximum allowable working pressure calculated from the tube thickness.
The maximum allowable working pressure of the fitting is limited from the value of this table according to the application regulations, and use it, please after considering the application regulations and the standard of used equipment.
2. There is a possibility that the seal decreases remarkably, and consult separately, please when it is used for a long time exceeding 400°C.

TUBE FITTINGS |

PHYSICAL DIFFERENCES AND MARKING

T-LOK METRIC FITTINGS:

Union ELBOW (see Fig. 1)

Union TEE (see Fig. 2)

Union (see Fig. 3)

A Nut: Stepped Shoulder Marked T-LOK·316·6M·XXXX

B Body: Stepped Shoulder Marked T-LOK·316·XXXX

T-LOK INCH FITTINGS:

Union ELBOW (see Fig. 4)

Union TEE (see Fig. 5)

Union (see Fig. 6)

C Nut: Shoulder Marked T-LOK·316·1/4·XXXX

D Body: Shoulder Marked T-LOK·316·XXXX

UNION ELBOW

• METRIC

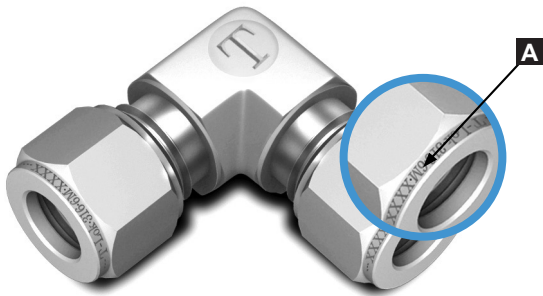

Fig. 1

• INCH

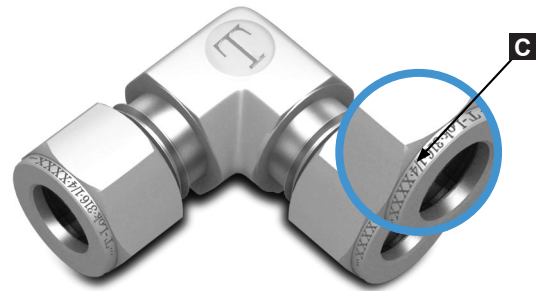

Fig. 4

UNION TEE

• METRIC



Fig. 2

• INCH



Fig. 5

UNION

• METRIC

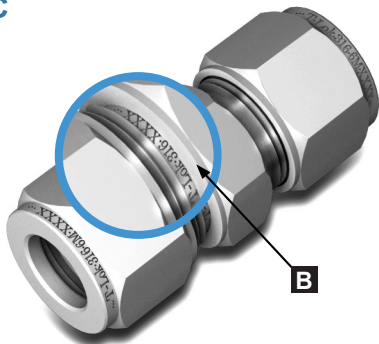

Fig. 3

• INCH

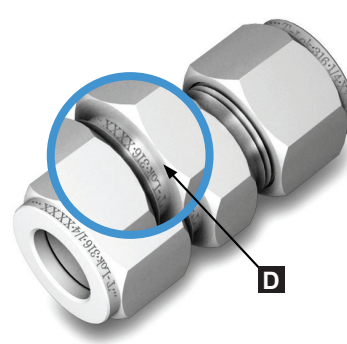

Fig. 6

Nut & Body of Metric type have Stepped Shoulder

T-LOK INSTALLATION INSTRUCTIONS

**T-LOK Fittings are supplied assembled and finger tight.
Disassembly before use can allow the entry of dirt or other particles.**

Step 1. Insert the tubing into the fitting.

Insert the tubing into T-LOK Tube Fitting's inside.
At this moment, Make sure that the tubing is completely contact with the shoulder of fittings and then finger-tighten the nut check that the tube rests firmly on the fitting shoulder and that the nut is finger tight.

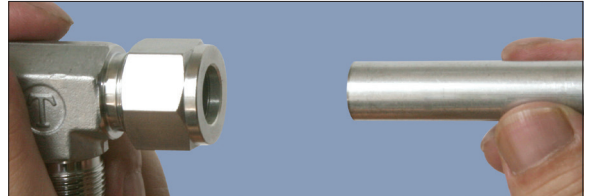

Step 2. Mark the starting point

Before tightening the T-LOK nut, it is recommended that a scribe mark be drawn on the hex of the nut extending onto the fitting body. This mark will serve as an indicator for the starting point and proper pull-up mark the starting point of turning at the 6 o'clock position.

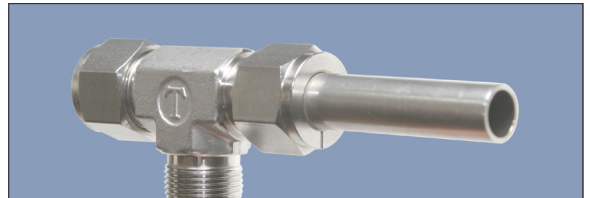

Step 3. Tighten the nut.

Hold the fitting body safely with a backup wrench and tighten the nut 1-1/4 (pay attention to the mark of starting point of turning, make one revolution and place at 9 o'clock position marking the starting point of turning at the 6 o'clock position will let you notice where the starting point is) 1-1/4 turns of the nut are required for 1/4" (6 mm) and higher 3/4 turn of the nut is required for 3/16" (4 mm) and lower

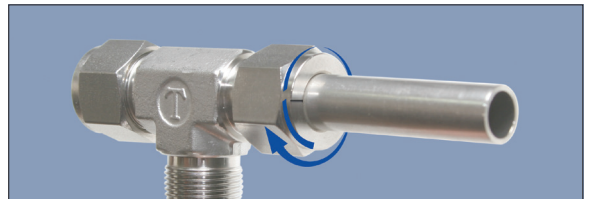

REASSEMBLY INSTRUCTIONS

T-LOK connections may be disconnected and remade repeatedly, without loss of leak tight seal.

1. Before disconnecting, mark the position of the nut in relation to the fitting body
2. To reassemble, use a wrench to tighten nut to original position.
3. Tighten slightly with wrench until a slight rise in torque is felt.

UNION

TU

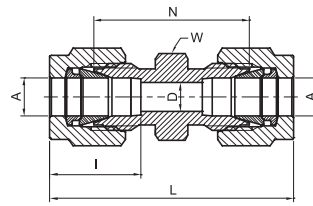

TUBE (METRIC) TO TUBE (METRIC)

Part Number	A Tube O.D.		D		W Hex. flat		N		L		I	
	mm	mm	mm	mm	mm	mm	mm	mm	mm	mm	mm	mm
TU - 2M	2		1.7		12		22.4		35.6		12.9	
TU - 3M	3		2.4		12		22.1		35.3		12.9	
TU - 4M	4		2.4		12		24.1		37.3		13.7	
TU - 6M	6		4.8		14		26.2		41.0		15.3	
TU - 8M	8		6.4		15		28.2		43.2		16.2	
TU - 10M	10		7.9		18		31.0		46.2		17.2	
TU - 12M	12		9.5		22		31.0		51.2		22.8	
TU - 14M	14		11.1		24		31.8		52.0		24.4	
TU - 15M	15		11.9		24		31.8		52.0		24.4	
TU - 16M	16		12.7		24		31.8		52.0		24.4	
TU - 18M	18		15.1		27		33.3		53.5		24.4	
TU - 20M	20		15.9		30		34.8		55.0		26.0	
TU - 22M	22		18.3		30		34.8		55.0		26.0	
TU - 25M	25		21.8		35		40.4		65.0		31.3	
TU - 28M	28		21.8		41		43.4		85.0		36.6	
TU - 32M	32		28.6		46		51.3		97.3		42.0	
TU - 38M	38		33.7		55		58.4		113.6		49.4	
TU - 42M	42		36.0		55		64.0		126.2		55.1	

TUBE (INCH) TO TUBE (INCH)

Part Number	A Tube O.D.		D		W Hex. flat		N		L		I	
	in	mm	in	mm	in	mm	in	mm	in	mm	in	mm
TU - 1	1/16	1.58	0.05	1.27	5/16	7.9	0.69	17.52	0.99	25.14	0.34	8.6
TU - 2	1/8	3.17	0.09	2.28	7/16	11.1	0.88	22.35	1.40	35.56	0.50	12.7
TU - 3	3/16	4.76	0.12	3.04	7/16	11.1	0.95	24.13	1.47	37.33	0.54	13.7
TU - 4	1/4	6.35	0.19	4.82	1/2	12.7	1.03	26.16	1.61	40.89	0.60	15.3
TU - 5	5/16	7.93	0.25	6.35	9/16	14.3	1.11	28.2	1.69	42.90	0.64	16.3
TU - 6	3/8	9.52	0.28	7.11	5/8	15.9	1.19	30.22	1.77	44.95	0.66	16.9
TU - 8	1/2	12.70	0.41	10.41	13/16	20.6	1.22	30.98	2.02	51.30	0.90	22.9
TU - 10	5/8	15.87	0.50	12.70	15/16	23.8	1.25	31.75	2.05	52.07	0.96	24.4
TU - 12	3/4	19.05	0.62	15.74	1-1/16	27.0	1.31	33.27	2.11	53.59	0.96	24.5
TU - 14	7/8	22.22	0.72	18.28	1-3/16	30.2	1.38	35.05	2.17	55.11	1.02	25.9
TU - 16	1	25.40	0.88	22.35	1-3/8	34.9	1.59	40.38	2.55	64.77	1.23	31.2
TU - 20	1-1/4	31.75	1.09	27.70	1-3/4	44.5	1.89	48.00	3.63	92.20	1.62	41.2
TU - 24	1-1/2	38.10	1.34	34.00	2-1/8	54.0	2.11	53.60	4.25	107.95	1.97	50.0
TU - 32	2	50.80	1.81	45.97	2-3/4	69.9	2.94	74.67	5.88	149.35	2.66	67.6

"D" - Dimension is minimum opening - dimensions are for reference only, and are subject to change without notice.

REDUCING UNION

TRU

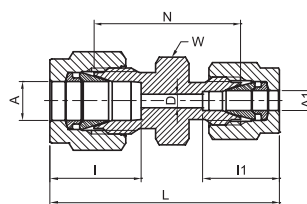

TUBE (METRIC) TO TUBE (METRIC)								
Part Number	A Tube O.D.	A1 Tube O.D.	D	W Hex. flat	N	L	I	I1
	mm	mm	mm	mm	mm	mm	mm	mm
TRU - 3M - 2M	3	2	1.7	12	22.1	35.3	12.9	12.9
TRU - 6M - 2M	6	2	1.7	14	24.6	38.6	15.9	12.9
TRU - 6M - 3M	6	3	2.4	14	24.6	38.6	15.9	12.9
TRU - 6M - 4M	6	4	2.4	14	25.4	39.4	15.9	13.7
TRU - 8M - 6M	8	6	4.8	15	27.4	42.3	16.2	15.3
TRU - 10M - 6M	10	6	4.8	18	29.5	44.5	17.2	15.3
TRU - 10M - 8M	10	8	6.4	18	30.0	45.1	17.2	16.2
TRU - 12M - 6M	12	6	4.8	22	29.5	47.0	22.8	15.3
TRU - 12M - 8M	12	8	6.4	22	30.2	47.8	22.8	16.2
TRU - 12M - 10M	12	10	7.9	22	31.0	48.7	22.8	17.2
TRU - 16M - 10M	16	10	7.9	24	31.8	49.5	24.4	17.2
TRU - 16M - 12M	16	12	9.5	24	31.8	52.0	24.4	22.8
TRU - 18M - 12M	18	12	9.5	27	33.3	53.5	24.4	22.8
TRU - 25M - 18M	25	18	15.1	35	38.6	61.0	31.3	24.4
TRU - 25M - 20M	25	20	15.9	35	39.9	62.3	31.3	26.0

TUBE (METRIC) TO TUBE (INCH)								
Part Number	A Tube O.D.	A1 Tube O.D.	D	W Hex. flat	N	L	I	I1
	mm	in	mm	mm	mm	mm	mm	mm
TRU - 2M - 4	2	1/4	1.7	14	24.0	38.6	12.9	15.3
TRU - 3M - 2	3	1/8	2.4	12	22.1	35.2	12.9	12.7
TRU - 4M - 2	4	1/8	2.4	12	23.4	36.5	13.7	12.7
TRU - 4M - 4	4	1/4	2.4	14	25.4	39.4	13.7	15.3
TRU - 6M - 2	6	1/8	2.4	14	24.6	38.5	15.3	12.7
TRU - 6M - 4	6	1/4	4.8	14	26.2	41.0	15.3	15.3
TRU - 6M - 5	6	5/16	4.8	14	27.4	42.3	15.3	16.2
TRU - 8M - 2	8	1/8	2.4	15	25.9	39.9	16.2	12.7
TRU - 8M - 4	8	1/4	4.8	15	27.4	42.3	16.2	15.3
TRU - 8M - 6	8	3/8	6.4	16	29.5	44.3	16.2	16.9
TRU - 10M - 2	10	1/8	2.4	18	27.1	41.8	17.2	12.7
TRU - 10M - 4	10	1/4	4.8	18	29.5	44.5	17.2	15.3
TRU - 10M - 5	10	5/16	6.4	18	30.0	45.1	17.2	16.2
TRU - 10M - 6	10	3/8	7.1	18	31.0	45.9	17.2	16.9
TRU - 12M - 5	12	5/16	6.4	22	30.2	47.8	22.8	16.2
TRU - 12M - 6	12	3/8	7.1	22	31.0	48.4	22.8	16.9
TRU - 12M - 8	12	1/2	9.5	22	31.0	51.2	22.8	22.9
TRU - 15M - 8	15	1/2	10.3	24	31.8	52.0	24.4	22.9
TRU - 16M - 10	16	5/8	12.7	24	31.8	52.0	24.4	24.4
TRU - 18M - 12	18	3/4	15.1	27	33.3	53.5	24.4	24.5

"D" - Dimension is minimum opening - dimensions are for reference only, and are subject to change without notice.

REDUCING UNION

TRU

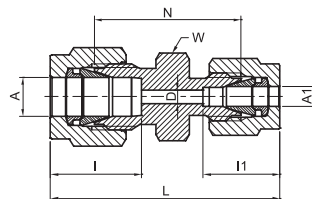
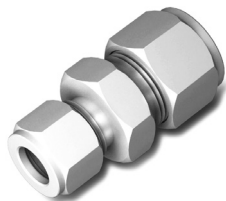

TUBE (INCH) TO TUBE (INCH)																
Part Number	A Tube O.D.		A1 Tube O.D.		D		W Hex. flat		N		L		I		I1	
	in	mm	in	mm	in	mm	in	mm	in	mm	in	mm	in	mm	in	mm
TRU - 2 - 1	1/8	3.17	1/16	1.58	0.05	1.27	7/16	11.1	0.81	20.57	1.22	30.98	0.50	12.7	0.34	8.6
TRU - 3 - 1	3/16	4.76	1/16	1.58	0.05	1.27	7/16	11.1	0.86	21.84	1.27	32.26	0.54	13.7	0.34	8.6
TRU - 3 - 2	3/16	4.76	1/8	3.17	0.09	2.28	7/16	11.1	0.92	23.36	1.44	36.57	0.54	13.7	0.50	12.7
TRU - 4 - 1	1/4	6.35	1/16	1.58	0.05	1.27	1/2	12.7	0.91	23.11	1.35	34.29	0.60	15.3	0.34	8.6
TRU - 4 - 2	1/4	6.35	1/8	3.17	0.09	2.28	1/2	12.7	0.97	24.63	1.52	38.60	0.60	15.3	0.50	12.7
TRU - 4 - 3	1/4	6.35	3/16	4.76	0.12	3.04	1/2	12.7	1.00	25.40	1.55	39.37	0.60	15.3	0.54	13.7
TRU - 5 - 2	5/16	7.93	1/8	3.17	0.09	2.28	9/16	14.3	1.01	25.65	1.56	39.62	0.64	16.3	0.50	12.7
TRU - 5 - 4	5/16	7.93	1/4	6.35	0.19	4.82	9/16	14.3	1.08	27.43	1.66	42.16	0.64	16.3	0.60	15.3
TRU - 6 - 1	3/8	9.52	1/16	1.58	0.05	1.27	5/8	15.9	1.00	25.40	1.44	36.58	0.66	16.9	0.34	8.6
TRU - 6 - 2	3/8	9.52	1/8	3.17	0.09	2.28	5/8	15.9	1.06	26.92	1.61	40.89	0.66	16.9	0.50	12.7
TRU - 6 - 4	3/8	9.52	1/4	6.35	0.19	4.82	5/8	15.9	1.12	28.44	1.70	43.18	0.66	16.9	0.60	15.3
TRU - 6 - 5	3/8	9.52	5/16	7.93	0.25	6.35	5/8	15.9	1.16	29.46	1.74	44.19	0.66	16.9	0.64	16.3
TRU - 8 - 2	1/2	12.70	1/8	3.17	0.09	2.28	13/16	20.6	1.12	28.44	1.78	45.21	0.90	22.9	0.50	12.7
TRU - 8 - 4	1/2	12.70	1/4	6.35	0.19	4.82	13/16	20.6	1.16	29.46	1.85	46.99	0.90	22.9	0.60	15.3
TRU - 8 - 6	1/2	12.70	3/8	9.52	0.28	7.11	13/16	20.6	1.22	30.98	1.91	48.51	0.90	22.9	0.66	16.9
TRU - 10 - 6	5/8	15.87	3/8	9.52	0.28	7.11	15/16	23.8	1.25	31.75	1.94	49.27	0.96	24.4	0.66	16.9
TRU - 10 - 8	5/8	15.87	1/2	12.70	0.41	10.41	15/16	23.8	1.25	31.75	2.05	52.07	0.96	24.4	0.90	22.9
TRU - 12 - 4	3/4	19.05	1/4	6.35	0.19	4.82	1-1/16	27.0	1.25	31.75	1.94	49.28	0.96	24.5	0.60	15.3
TRU - 12 - 6	3/4	19.05	3/8	9.52	0.28	7.11	1-1/16	27.0	1.31	33.27	2.00	50.80	0.96	24.5	0.66	16.9
TRU - 12 - 8	3/4	19.05	1/2	12.70	0.41	10.41	1-1/16	27.0	1.31	33.27	2.11	53.59	0.96	24.5	0.90	22.9
TRU - 12 - 10	3/4	19.05	5/8	15.87	0.50	12.70	1-1/16	27.0	1.31	33.27	2.11	53.59	0.96	24.5	0.96	24.4
TRU - 16 - 8	1	25.40	1/2	12.70	0.41	10.41	1-3/8	34.9	1.59	40.38	2.38	60.45	1.23	31.2	0.90	22.9
TRU - 16 - 12	1	25.40	3/4	19.05	0.62	15.75	1-3/8	34.9	1.59	40.38	2.38	60.45	1.23	31.2	0.96	24.5

"D" - Dimension is minimum opening - dimensions are for reference only, and are subject to change without notice.

UNION TEE

TUT

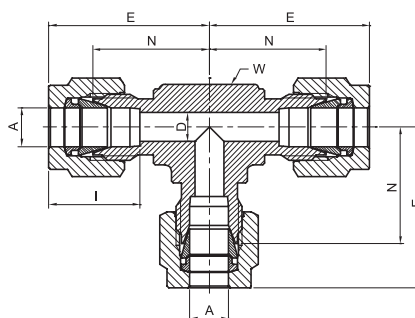
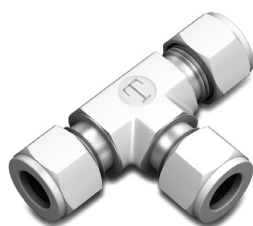

ALL TUBE (METRIC)									
Part Number	A Tube O.D.		D		W Hex. flat		N	E	I
	mm	mm	in	mm	mm	mm	mm	mm	mm
TUT - 2M	2	1.7	3/8	9.5	15.7	22.3	12.9		
TUT - 3M	3	2.4	3/8	9.5	15.7	22.3	12.9		
TUT - 4M	4	2.4	1/2	12.7	18.8	25.4	13.7		
TUT - 6M	6	4.8	1/2	12.7	19.6	27.0	15.3		
TUT - 8M	8	6.4	5/8	15.9	22.4	29.9	16.2		
TUT - 10M	10	7.9	11/16	17.5	23.9	31.5	17.2		
TUT - 12M	12	9.5	13/16	20.6	25.9	36.0	22.8		
TUT - 14M	14	11.1	15/16	23.8	28.7	38.8	24.4		
TUT - 15M	15	11.9	15/16	23.8	28.7	38.8	24.4		
TUT - 16M	16	12.7	15/16	23.8	28.7	38.8	24.4		
TUT - 18M	18	15.1	1-1/8	28.6	29.7	39.8	24.4		
TUT - 20M	20	15.9	1-3/8	34.9	34.5	44.6	26.0		
TUT - 22M	22	18.3	1-3/8	34.9	34.5	44.6	26.0		
TUT - 25M	25	21.8	1-3/8	34.9	36.8	49.1	31.3		
TUT - 28M	28	21.8	-	41.0	43.2	64.0	36.8		
TUT - 32M	32	28.6	-	46.0	49.3	72.3	42.0		
TUT - 38M	38	33.7	-	55.0	56.4	84.0	49.4		
TUT - 42M	42	36.0	-	55.0	58.0	89.1	55.1		

ALL TUBE (INCH)												
Part Number	A Tube O.D.		D		W Hex. flat		N		E		I	
	in	mm	in	mm	in	mm	in	mm	in	mm	in	mm
TUT - 1	1/16	1.58	0.05	1.27	3/8	9.5	0.56	14.00	0.70	17.80	0.34	8.6
TUT - 2	1/8	3.17	0.09	2.28	3/8	9.5	0.62	15.74	0.88	22.35	0.50	12.7
TUT - 3	3/16	4.76	0.12	3.04	1/2	12.7	0.70	17.80	0.96	24.40	0.54	13.7
TUT - 4	1/4	6.35	0.19	4.82	1/2	12.7	0.77	19.60	1.06	26.90	0.60	15.3
TUT - 5	5/16	7.93	0.25	6.35	5/8	15.9	0.88	22.35	1.17	29.71	0.64	16.3
TUT - 6	3/8	9.52	0.28	7.11	5/8	15.9	0.91	23.11	1.20	30.48	0.66	16.9
TUT - 8	1/2	12.70	0.41	10.41	13/16	20.6	1.02	25.90	1.42	36.10	0.90	22.9
TUT - 10	5/8	15.87	0.50	12.70	15/16	23.8	1.13	28.70	1.53	38.90	0.96	24.4
TUT - 12	3/4	19.05	0.62	15.74	1-1/16	27.0	1.17	29.70	1.57	39.90	0.96	24.5
TUT - 14	7/8	22.22	0.72	18.29	1-3/8	34.9	1.36	34.54	1.76	44.70	1.02	25.9
TUT - 16	1	25.40	0.88	22.35	1-3/8	34.9	1.45	36.80	1.93	49.00	1.23	31.2
TUT - 20	1-1/4	31.75	1.09	27.70	1-11/16	42.9	1.75	44.50	2.62	66.65	1.62	41.2
TUT - 24	1-1/2	38.10	1.34	34.00	2	50.8	2.00	50.80	3.07	77.98	1.97	50.0
TUT - 32	2	50.80	1.81	45.97	2-3/4	69.9	2.75	69.85	4.22	107.19	2.66	67.6

"D" - Dimension is minimum opening - dimensions are for reference only, and are subject to change without notice.

REDUCING UNION TEE

TRUT

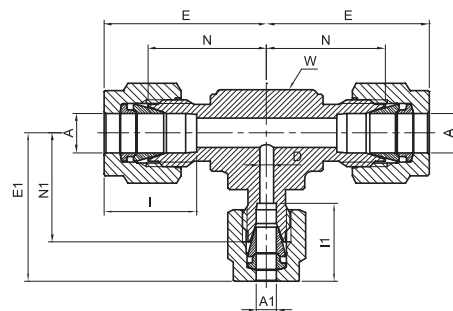
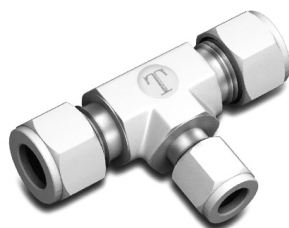

TUBE (INCH) TO TUBE (INCH)																				
Part Number	A Tube O.D.		A1 Tube O.D.		E		E1		I		I1		D		W Hex. flat		N		N1	
	in	mm	in	mm	in	mm	in	mm	in	mm	in	mm	in	mm	in	mm	in	mm	in	mm
TRUT - 6 - 6 - 4	3/8	9.52	1/4	6.35	1.20	30.5	1.14	29.0	0.66	16.9	0.60	15.3	0.19	4.8	5/8	15.9	0.91	23.1	0.85	21.6
TRUT - 8 - 8 - 4	1/2	12.70	1/4	6.35	1.42	36.1	1.25	31.8	0.90	22.9	0.60	15.3	0.19	4.8	13/16	20.6	1.02	25.9	0.96	24.4
TRUT - 8 - 8 - 6	1/2	12.70	3/8	9.52	1.42	36.1	1.31	33.3	0.90	22.9	0.66	16.9	0.28	7.1	13/16	20.6	1.02	25.9	1.02	25.9
TRUT - 10 - 10 - 6	5/8	15.88	3/8	9.52	1.53	38.9	1.42	36.1	0.96	24.4	0.66	16.9	0.28	7.1	15/16	23.8	1.13	28.7	1.13	28.7
TRUT - 12 - 12 - 6	3/4	19.05	3/8	9.52	1.57	39.9	1.46	37.1	0.96	24.5	0.66	16.9	0.28	7.1	1-1/16	27.0	1.17	29.7	1.17	29.7
TRUT - 12 - 12 - 8	3/4	19.05	1/2	12.70	1.57	39.9	1.57	39.9	0.96	24.5	0.90	22.9	0.41	10.4	1-1/16	27.0	1.17	29.7	1.17	29.7
TRUT - 16 - 16 - 6	1	25.4	3/8	9.52	1.93	49.0	1.65	41.9	1.23	31.2	0.66	16.9	0.28	7.1	1-3/8	34.9	1.45	36.8	1.36	34.5
TRUT - 16 - 16 - 8	1	25.4	1/2	12.70	1.93	49.0	1.76	44.7	1.23	31.2	0.90	22.9	0.41	10.4	1-3/8	34.9	1.45	36.8	1.36	34.5
TRUT - 16 - 16 - 12	1	25.4	3/4	19.05	1.93	49.0	1.76	44.7	1.23	31.2	0.96	24.5	0.62	15.8	1-3/8	34.9	1.45	36.8	1.36	34.5

HOW TO ORDER

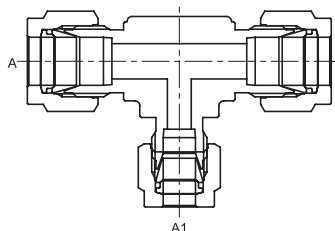
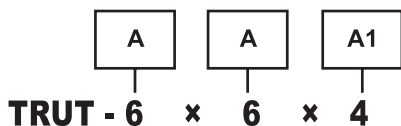

TUBE (INCH) TO TUBE (INCH)																				
Part Number	A Tube O.D.		A1 Tube O.D.		E		E1		I		I1		D		W Hex. flat		N		N1	
	in	mm	in	mm	in	mm	in	mm	in	mm	in	mm	in	mm	in	mm	in	mm	in	mm
TRUT - 6 - 4 - 6	3/8	9.52	1/4	6.35	1.20	30.5	1.14	29.0	0.66	16.9	0.60	15.3	0.19	4.8	5/8	15.9	0.91	23.1	0.85	21.6

"D" - Dimension is minimum opening - dimensions are for reference only, and are subject to change without notice.

REDUCING UNION TEE

TRUT

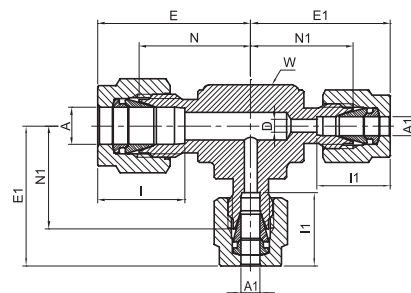
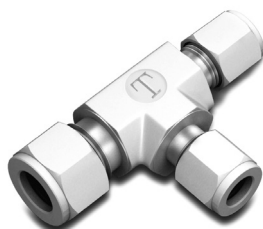

TUBE (INCH) TO TUBE (INCH)																				
Part Number	A Tube O.D.		A1 Tube O.D.		E		E1		I		I1		D		W Hex. flat		N		N1	
	in	mm	in	mm	in	mm	in	mm	in	mm	in	mm	in	mm	in	mm	in	mm	in	mm
TRUT - 8 - 6 - 6	1/2	12.70	3/8	9.52	1.42	36.1	1.31	33.3	0.90	22.9	0.66	16.9	0.28	7.1	13/16	20.6	1.02	25.9	1.02	25.9
TRUT - 10 - 6 - 6	5/8	15.88	3/8	9.52	1.53	38.9	1.42	36.1	0.96	24.4	0.66	16.9	0.28	7.1	15/16	23.8	1.13	28.7	1.13	28.7
TRUT - 12 - 6 - 6	3/4	19.05	3/8	9.52	1.57	39.9	1.46	37.1	0.96	24.5	0.66	16.9	0.28	7.1	1-1/16	27.0	1.17	29.7	1.17	29.7

HOW TO ORDER

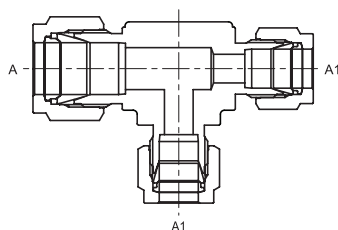
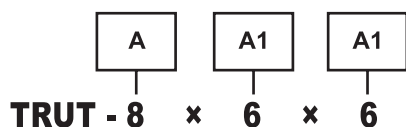

TUBE (INCH) TO TUBE (INCH)																										
Part Number	A Tube O.D.		A1 Tube O.D.		A2 Tube O.D.		E		E1		E2		I		I1		I2		D		W Hex. flat		N		N1+N2	
	in	mm	in	mm	in	mm	in	mm	in	mm	in	mm	in	mm	in	mm	in	mm	in	mm	in	mm	in	mm	in	mm
TRUT - 10 - 8 - 6	5/8	15.88	1/2	12.7	3/8	9.52	1.53	38.9	1.53	38.9	1.42	36.1	0.96	24.4	0.9	22.9	0.66	16.9	0.28	7.1	15/16	23.8	1.13	28.7	1.13	28.7
TRUT - 12 - 8 - 6	3/4	19.05	1/2	12.7	3/8	9.52	1.57	39.9	1.57	39.9	1.46	37.1	0.96	24.5	0.9	22.9	0.66	16.9	0.28	7.1	1-1/16	27.0	1.17	29.7	1.17	29.7
TRUT - 16 - 12 - 6	1	25.4	3/4	19.05	3/8	9.52	1.93	49	1.76	44.7	1.65	41.9	1.23	31.2	0.96	24.5	0.66	16.9	0.28	7.1	1 3/8	34.9	1.45	36.8	1.36	34.5

HOW TO ORDER

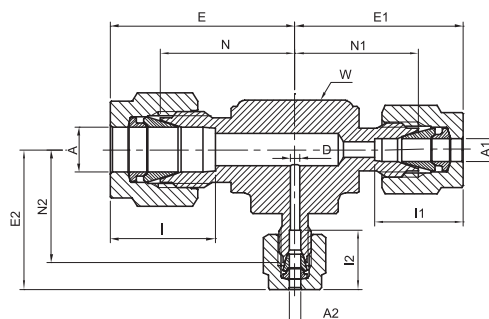
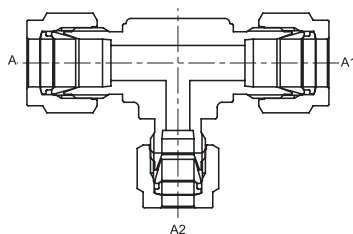
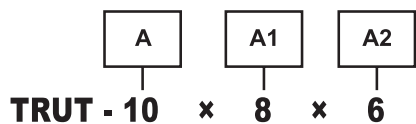

"D" - Dimension is minimum opening - dimensions are for reference only, and are subject to change without notice.

UNION 90° ELBOW

TUE

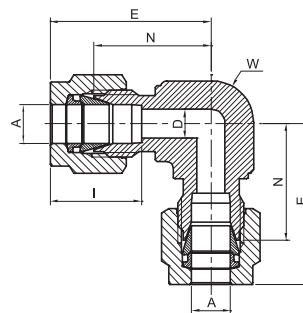

TUBE (METRIC) TO TUBE (METRIC)

Part Number	A Tube O.D.		D		W Hex. flat		N		E		I	
	mm	mm	mm	mm	in	mm	mm	mm	mm	mm	mm	mm
TUE - 3M	3		2.4		3/8	9.5		15.7		22.3		12.9
TUE - 4M	4		2.4		1/2	12.7		18.8		25.4		13.7
TUE - 6M	6		4.8		1/2	12.7		19.6		27.0		15.3
TUE - 8M	8		6.4		9/16	14.3		21.3		28.8		16.2
TUE - 10M	10		7.9		11/16	17.5		23.9		31.5		17.2
TUE - 12M	12		9.5		13/16	20.6		25.9		36.0		22.8
TUE - 14M	14		11.1		15/16	23.8		27.9		38.0		24.4
TUE - 15M	15		11.9		15/16	23.8		27.9		38.0		24.4
TUE - 16M	16		12.7		15/16	23.8		27.9		38.0		24.4
TUE - 18M	18		15.1		1-1/8	28.6		29.7		39.8		24.4
TUE - 20M	20		15.9		1-3/8	34.9		34.5		44.6		26.0
TUE - 22M	22		18.3		1-3/8	34.9		34.5		44.6		26.0
TUE - 25M	25		21.8		1-3/8	34.9		36.8		49.1		31.3
TUE - 28M	28		21.8		-	41.0		43.2		64		36.6
TUE - 32M	32		28.6		-	46.0		49.3		72.3		42.0
TUE - 38M	38		33.7		-	55.0		56.4		84		49.4
TUE - 42M	42		36.0		-	55.0		58		89.1		55.1

TUBE (INCH) TO TUBE (INCH)

Part Number	A Tube O.D.		D		W Hex. flat		N		E		I	
	in	mm	in	mm	in	mm	in	mm	in	mm	in	mm
TUE - 1	1/16	1.58	0.05	1.25	3/8	9.5	0.55	14.00	0.70	17.80	0.34	8.6
TUE - 2	1/8	3.17	0.09	2.28	3/8	9.5	0.62	15.74	0.88	22.35	0.50	12.7
TUE - 3	3/16	4.76	0.12	3.04	1/2	12.7	0.74	18.80	1.00	25.40	0.54	13.7
TUE - 4	1/4	6.35	0.19	4.82	1/2	12.7	0.77	19.60	1.06	26.92	0.60	15.32
TUE - 5	5/16	7.93	0.25	6.35	9/16	14.3	0.84	21.33	1.13	28.70	0.64	16.3
TUE - 6	3/8	9.52	0.28	7.11	5/8	15.9	0.91	23.11	1.20	30.48	0.66	16.9
TUE - 8	1/2	12.70	0.41	10.41	13/16	20.6	1.02	25.90	1.42	36.06	0.90	22.9
TUE - 10	5/8	15.87	0.50	12.70	15/16	23.8	1.10	27.94	1.50	38.10	0.96	24.4
TUE - 12	3/4	19.05	0.62	15.74	1-1/16	27.0	1.17	29.70	1.57	39.89	0.96	24.5
TUE - 14	7/8	22.22	0.72	18.28	1-3/8	34.9	1.36	34.5	1.76	44.70	1.02	25.9
TUE - 16	1	25.40	0.88	22.35	1-3/8	34.9	1.45	36.83	1.93	49.00	1.23	31.2
TUE - 20	1-1/4	31.75	1.09	27.70	1-11/16	42.9	1.75	44.50	2.62	66.55	1.62	41.2
TUE - 24	1-1/2	38.10	1.34	34.00	2	50.8	2.00	50.80	3.07	77.98	1.97	50.0
TUE - 32	2	50.80	1.81	45.97	2-3/4	69.9	2.75	69.85	4.22	107.19	2.66	67.6

"D" - Dimension is minimum opening - dimensions are for reference only, and are subject to change without notice.

FEMALE CONNECTOR

TFC

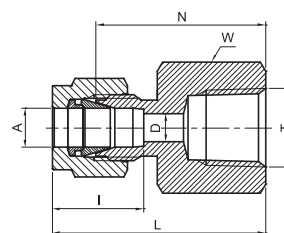

TUBE (METRIC) TO FEMALE NPT THREAD							
Part Number	A Tube O.D.	T NPT	D	W Hex. flat	N	L	I
	mm	in	mm	mm	mm	mm	mm
TFC - 3M - 2N	3	1/8	2.4	14	22.1	28.7	12.7
TFC - 3M - 4N	3	1/4	2.4	19	26.9	33.5	12.7
TFC - 4M - 2N	4	1/8	2.4	14	23.1	29.7	13.7
TFC - 6M - 2N	6	1/8	4.8	14	23.9	31.3	15.3
TFC - 6M - 4N	6	1/4	4.8	19	28.4	35.8	15.3
TFC - 6M - 6N	6	3/8	4.8	22	30.2	37.6	15.3
TFC - 6M - 8N	6	1/2	4.8	27	35.1	42.5	15.3
TFC - 8M - 2N	8	1/8	6.4	15	24.6	32.1	16.2
TFC - 8M - 4N	8	1/4	6.4	19	29.5	37.0	16.2
TFC - 8M - 6N	8	3/8	6.4	22	31.0	38.5	16.2
TFC - 8M - 8N	8	1/2	6.4	27	35.8	43.3	16.2
TFC - 10M - 4N	10	1/4	7.9	19	30.2	37.8	17.2
TFC - 10M - 6N	10	3/8	7.9	22	31.8	39.4	17.2
TFC - 10M - 8N	10	1/2	7.9	27	36.6	44.2	17.2
TFC - 12M - 4N	12	1/4	9.5	22	30.2	40.3	22.8
TFC - 12M - 6N	12	3/8	9.5	22	31.8	41.9	22.8
TFC - 12M - 8N	12	1/2	9.5	27	36.6	46.7	22.8
TFC - 15M - 8N	15	1/2	11.9	27	36.6	46.7	24.4
TFC - 16M - 8N	16	1/2	12.7	27	36.8	46.9	24.4
TFC - 20M - 8N	20	1/2	15.9	30	37.8	47.9	26.0
TFC - 20M - 12N	20	3/4	15.9	35	39.6	49.7	26.0
TFC - 22M - 12N	22	3/4	18.3	35	39.6	49.7	26.0
TFC - 22M - 16N	22	1	18.3	41	47.8	57.9	26.0
TFC - 25M - 12N	25	3/4	21.8	35	41.1	53.4	31.3
TFC - 25M - 16N	25	1	21.8	41	50.0	62.3	31.3

"D" - Dimension is minimum opening - dimensions are for reference only, and are subject to change without notice.

FEMALE CONNECTOR

TFC

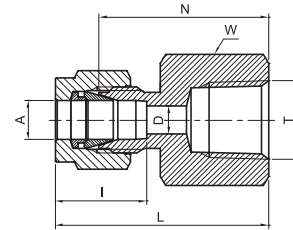

TUBE (INCH) TO FEMALE NPT THREAD													
Part Number	A Tube O.D.		T NPT	D		W Hex. flat		N		L		I	
	in	mm	in	in	mm	in	mm	in	mm	in	mm	in	mm
TFC - 1 - 1N	1/16	1.58	1/16	0.05	1.27	7/16	11.1	0.78	19.81	0.93	23.62	0.34	8.6
TFC - 1 - 2N	1/16	1.58	1/8	0.05	1.27	9/16	14.3	0.81	20.57	0.96	24.38	0.34	8.6
TFC - 2 - 2N	1/8	3.17	1/8	0.09	2.28	9/16	14.3	0.87	22.10	1.13	28.70	0.50	12.7
TFC - 2 - 4N	1/8	3.17	1/4	0.09	2.28	3/4	19.1	1.06	26.92	1.32	33.52	0.50	12.7
TFC - 3 - 2N	3/16	4.76	1/8	0.12	3.04	9/16	14.3	0.91	23.11	1.17	29.71	0.54	13.7
TFC - 4 - 2N	1/4	6.35	1/8	0.19	4.82	9/16	14.3	0.94	23.87	1.23	31.24	0.60	15.3
TFC - 4 - 4N	1/4	6.35	1/4	0.19	4.82	3/4	19.1	1.12	28.44	1.41	35.81	0.60	15.3
TFC - 4 - 6N	1/4	6.35	3/8	0.19	4.82	7/8	22.2	1.19	30.22	1.48	37.59	0.60	15.3
TFC - 4 - 8N	1/4	6.35	1/2	0.19	4.82	1-1/16	27.0	1.38	35.0	1.67	42.42	0.60	15.3
TFC - 5 - 2N	5/16	7.93	1/8	0.25	6.35	9/16	14.3	0.97	24.63	1.26	32.00	0.64	16.3
TFC - 5 - 4N	5/16	7.93	1/4	0.25	6.35	3/4	19.1	1.16	29.46	1.45	36.83	0.64	16.3
TFC - 6 - 2N	3/8	9.52	1/8	0.28	7.11	5/8	15.9	1.00	25.40	1.29	32.76	0.66	16.9
TFC - 6 - 4N	3/8	9.52	1/4	0.28	7.11	3/4	19.1	1.19	30.22	1.48	37.59	0.66	16.9
TFC - 6 - 6N	3/8	9.52	3/8	0.28	7.11	7/8	22.2	1.25	31.75	1.54	39.11	0.66	16.9
TFC - 6 - 8N	3/8	9.52	1/2	0.28	7.11	1-1/16	27.0	1.44	36.57	1.73	43.94	0.66	16.9
TFC - 6 - 12N	3/8	9.52	3/4	0.28	7.11	1-5/16	33.3	1.59	40.38	1.88	47.75	0.66	16.9
TFC - 8 - 4N	1/2	12.70	1/4	0.41	10.41	13/16	20.6	1.19	30.2	1.59	40.38	0.90	22.9
TFC - 8 - 6N	1/2	12.70	3/8	0.41	10.41	7/8	22.2	1.25	31.75	1.65	41.91	0.90	22.9
TFC - 8 - 8N	1/2	12.70	1/2	0.41	10.41	1-1/16	27.0	1.44	36.57	1.84	46.73	0.90	22.9
TFC - 8 - 12N	1/2	12.70	3/4	0.41	10.41	1-5/16	33.3	1.50	38.10	1.90	48.26	0.90	22.9
TFC - 10 - 6N	5/8	15.87	3/8	0.50	12.70	5/16	23.8	1.25	31.75	1.65	41.91	0.96	24.4
TFC - 10 - 8N	5/8	15.87	1/2	0.50	12.70	1-1/16	27.0	1.44	36.57	1.84	46.73	0.96	24.4
TFC - 10 - 12N	5/8	15.87	3/4	0.5	12.7	1-5/16	33.3	1.50	38.1	1.90	48.26	0.96	24.4
TFC - 12 - 8N	3/4	19.05	1/2	0.62	15.74	1-1/16	27.0	1.44	36.57	1.84	46.73	0.96	24.5
TFC - 12 - 12N	3/4	19.05	3/4	0.62	15.74	1-5/16	33.3	1.50	38.10	1.90	48.26	0.96	24.5
TFC - 14 - 12N	7/8	22.22	3/4	0.72	18.28	1-5/16	33.3	1.56	39.62	1.96	49.78	1.02	25.9
TFC - 16 - 12N	1	25.40	3/4	0.88	22.35	1-3/8	34.9	1.62	41.14	2.10	53.34	1.23	31.2
TFC - 16 - 16N	1	25.4	1	0.88	22.35	1-5/8	41.3	1.97	50.03	2.45	62.23	1.23	31.2
TFC - 20 - 20N	1-1/4	31.75	1-1/4	1.09	27.7	2-1/8	54	2.07	52.59	2.94	74.68	1.62	41.2
TFC - 24 - 24N	1-1/2	38.1	1-1/2	1.34	34.0	2-3/8	60.3	2.21	56.13	3.28	83.31	1.97	50.0
TFC - 32 - 32N	2	50.8	2	1.81	45.97	2-7/8	73	2.53	64.26	4.0	101.6	2.66	67.6

"D" - Dimension is minimum opening - dimensions are for reference only, and are subject to change without notice.

FEMALE CONNECTOR

TFC

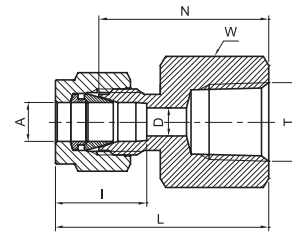

TUBE (METRIC) TO FEMALE ISO TAPERED THREAD							
Part Number	A	T	D	W	N	L	I
	Tube O.D.	ISO		Hex. flat			
	mm	in	mm	mm	mm	mm	mm
TFC - 3M - 2P	3	Rc 1/8	2.4	14	22.1	28.7	12.9
TFC - 6M - 2P	6	Rc 1/8	4.8	14	23.9	31.3	15.3
TFC - 6M - 4P	6	Rc 1/4	4.8	19	28.4	35.8	15.3
TFC - 6M - 6P	6	Rc 3/8	4.8	22	30.2	37.6	15.3
TFC - 6M - 8P	6	Rc 1/2	4.8	27	35.1	42.5	15.3
TFC - 8M - 2P	8	Rc 1/8	6.4	15	24.6	32.1	16.2
TFC - 8M - 4P	8	Rc 1/4	6.4	19	29.5	37.0	16.2
TFC - 8M - 6P	8	Rc 3/8	6.4	22	31.0	38.5	16.2
TFC - 8M - 8P	8	Rc 1/2	6.4	27	35.8	43.3	16.2
TFC - 10M - 2P	10	Rc 1/8	7.9	18	25.4	33.0	17.2
TFC - 10M - 4P	10	Rc 1/4	7.9	19	30.2	37.8	17.2
TFC - 10M - 6P	10	Rc 3/8	7.9	22	31.8	39.4	17.2
TFC - 10M - 8P	10	Rc 1/2	7.9	27	36.6	44.2	17.2
TFC - 12M - 2P	12	Rc 1/8	9.5	22	25.4	35.5	22.8
TFC - 12M - 4P	12	Rc 1/4	9.5	22	30.2	40.3	22.8
TFC - 12M - 6P	12	Rc 3/8	9.5	22	31.8	41.9	22.8
TFC - 12M - 8P	12	Rc 1/2	9.5	27	36.6	46.7	22.8
TFC - 12M - 12P	12	Rc 3/4	9.5	35	38.9	49.0	22.8
TFC - 15M - 6P	15	Rc 3/8	11.9	24	31.8	41.9	24.4
TFC - 15M - 8P	15	Rc 1/2	11.9	27	36.6	46.7	24.4
TFC - 20M - 8P	20	Rc 1/2	15.9	30	37.8	47.9	24.4
TFC - 20M - 12P	20	Rc 3/4	15.9	35	39.6	49.7	26.0
TFC - 22M - 12P	22	Rc 3/4	18.3	35	39.6	49.7	26.0
TFC - 22M - 16P	22	Rc 1	18.3	41	47.8	57.9	26.0
TFC - 25M - 12P	25	Rc 3/4	21.8	35	41.1	53.4	31.3
TFC - 25M - 16P	25	Rc 1	21.8	41	50.0	62.3	31.3

Reference Specifications :

- DIN - ISO 2999 •55° Thread angle
- BS - 21 •Truncation of root and crest are round
- JIS - B0203 •Taper angle 1° 47'

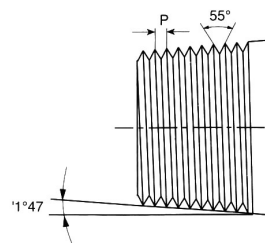

"D" - Dimension is minimum opening - dimensions are for reference only, and are subject to change without notice.

FEMALE CONNECTOR

TFC

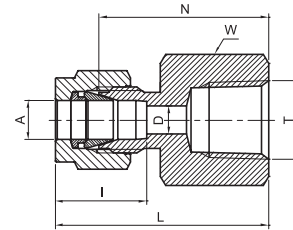

TUBE (INCH) TO FEMALE ISO TAPERED THREAD

Part Number	A Tube O.D.		T ISO	D		W Hex. flat		N		L		I	
	in	mm	in	in	mm	in	mm	in	mm	in	mm	in	mm
TFC - 1 - 1P	1/16	1.58	Rc 1/16	0.05	1.27	7/16	11.1	0.78	19.81	0.93	23.62	0.34	8.6
TFC - 1 - 2P	1/16	1.58	Rc 1/8	0.05	1.27	9/16	14.3	0.81	20.57	0.96	24.38	0.34	8.6
TFC - 2 - 2P	1/8	3.17	Rc 1/8	0.09	2.28	9/16	14.3	0.87	22.10	1.13	28.70	0.50	12.7
TFC - 2 - 4P	1/8	3.17	Rc 1/4	0.09	2.28	3/4	19.1	1.06	26.92	1.32	33.52	0.50	12.7
TFC - 3 - 2P	3/16	4.76	Rc 1/8	0.12	3.04	9/16	14.3	0.91	23.11	1.17	29.71	0.54	13.7
TFC - 4 - 2P	1/4	6.35	Rc 1/8	0.19	4.82	9/16	14.3	0.94	23.87	1.23	31.24	0.60	15.3
TFC - 4 - 4P	1/4	6.35	Rc 1/4	0.19	4.82	3/4	19.1	1.12	28.44	1.41	35.81	0.60	15.3
TFC - 4 - 6P	1/4	6.35	Rc 3/8	0.19	4.82	7/8	22.2	1.19	30.22	1.48	37.59	0.60	15.3
TFC - 4 - 8P	1/4	6.35	Rc 1/2	0.19	4.82	1-1/16	27.0	1.38	35.0	1.67	42.42	0.60	15.3
TFC - 5 - 2P	5/16	7.93	Rc 1/8	0.25	6.35	9/16	14.3	0.97	24.63	1.26	32.00	0.64	16.3
TFC - 5 - 4P	5/16	7.93	Rc 1/4	0.25	6.35	3/4	19.1	1.16	29.46	1.45	36.83	0.64	16.3
TFC - 6 - 2P	3/8	9.52	Rc 1/8	0.28	7.11	5/8	15.9	1.00	25.40	1.29	32.76	0.66	16.9
TFC - 6 - 4P	3/8	9.52	Rc 1/4	0.28	7.11	3/4	19.1	1.19	30.22	1.48	37.59	0.66	16.9
TFC - 6 - 6P	3/8	9.52	Rc 3/8	0.28	7.11	7/8	22.2	1.25	31.75	1.54	39.11	0.66	16.9
TFC - 6 - 8P	3/8	9.52	Rc 1/2	0.28	7.11	1-1/16	27.0	1.44	36.57	1.73	43.94	0.66	16.9
TFC - 6 - 12P	3/8	9.52	Rc 3/4	0.28	7.11	1-5/16	33.3	1.59	40.38	1.88	47.75	0.66	16.9
TFC - 8 - 4P	1/2	12.70	Rc 1/4	0.41	10.41	13/16	20.6	1.19	30.2	1.59	40.38	0.90	22.9
TFC - 8 - 6P	1/2	12.70	Rc 3/8	0.41	10.41	7/8	22.2	1.25	31.75	1.65	41.91	0.90	22.9
TFC - 8 - 8P	1/2	12.70	Rc 1/2	0.41	10.41	1-1/16	27.0	1.44	36.57	1.84	46.73	0.90	22.9
TFC - 8 - 12P	1/2	12.70	Rc 3/4	0.41	10.41	1-5/16	33.3	1.50	38.10	1.90	48.26	0.90	22.9
TFC - 10 - 6P	5/8	15.87	Rc 3/8	0.50	12.70	15/16	23.8	1.25	31.75	1.65	41.91	0.96	24.4
TFC - 10 - 8P	5/8	15.87	Rc 1/2	0.50	12.70	1-1/16	27.0	1.44	36.57	1.84	46.73	0.96	24.4
TFC - 10 - 12P	5/8	15.87	Rc 3/4	0.5	12.7	1-5/16	33.3	1.50	38.1	1.90	48.26	0.96	24.4
TFC - 12 - 8P	3/4	19.05	Rc 1/2	0.62	15.74	1-1/16	27.0	1.44	36.57	1.84	46.73	0.96	24.5
TFC - 12 - 12P	3/4	19.05	Rc 3/4	0.62	15.74	1-5/16	33.3	1.50	38.10	1.90	48.26	0.96	24.5
TFC - 14 - 12P	7/8	22.22	Rc 3/4	0.72	18.28	1-5/16	33.3	1.56	39.62	1.96	49.78	1.02	25.9
TFC - 16 - 12P	1	25.40	Rc 3/4	0.88	22.35	1-3/8	34.9	1.62	41.14	2.10	53.34	1.23	31.2
TFC - 16 - 16P	1	25.40	Rc 1	0.88	22.35	1-5/8	41.3	1.97	50.03	2.45	62.23	1.23	31.2
TFC - 20 - 20P	1-1/4	31.75	1-1/4	1.09	27.7	2-1/8	54.0	2.07	52.59	2.94	74.68	1.62	41.2
TFC - 24 - 24P	1-1/2	38.1	1-1/2	1.34	34.0	2-3/8	60.3	2.21	56.13	3.28	83.31	1.97	50.0
TFC - 32 - 32P	2	50.8	2	1.81	45.97	2-7/8	73.0	2.53	64.26	4.0	101.6	2.66	67.6

"D" - Dimension is minimum opening - dimensions are for reference only, and are subject to change without notice.

FEMALE CONNECTOR

TFC

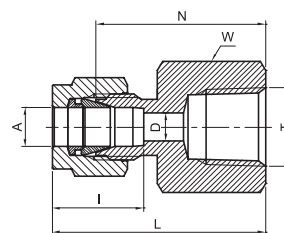

TUBE(METRIC) TO FEMALE ISO PARALLEL THREAD								
Part Number	A Tube O.D.		T ISO	D	W Hex. Flat	N	L	I
	mm		mm	mm	mm	mm	mm	mm
TFC-6M-4RP	6		G 1/4	4.8	19	32.0	39.4	15.3
TFC-6M-6RP	6		G 3/8	4.8	22	33.8	41.2	15.3
TFC-8M-6RP	8		G 3/8	6.4	22	34.6	42.1	16.2
TFC-8M-8RP	8		G 1/2	6.4	27	30.6	46.9	16.2
TFC-10M-8RP	10		G 1/2	7.9	27	40.2	47.8	17.2
TFC-12M-8RP	12		G 1/2	9.5	27	40.2	50.3	22.8
TFC-12M-12RP	12		G 3/4	9.5	35	40.5	50.6	22.8

TUBE(INCH) TO FEMALE ISO PARALLEL THREAD													
Part Number	A Tube O.D.		T ISO	D		W Hex. Flat		N		L		I	
	in	mm	in	in	mm	in	mm	in	mm	in	mm	in	mm
TFC-2-2RP	1/8	3.17	G 1/8	0.09	2.28	9/16	14.3	0.96	24.30	1.22	30.90	0.50	12.7
TFC-2-4RP	1/8	3.17	G 1/4	0.09	2.28	3/4	19.1	1.20	30.52	1.46	37.12	0.50	12.7
TFC-4-4RP	1/4	6.35	G 1/4	0.19	4.82	3/4	19.1	1.26	32.04	1.55	39.41	0.60	15.3
TFC-4-6RP	1/4	6.35	G 3/8	0.19	4.82	7/8	22.2	1.33	33.82	1.62	41.19	0.60	15.3
TFC-6-6RP	3/8	9.52	G 3/8	0.28	7.11	7/8	22.2	1.39	35.35	1.68	42.71	0.66	16.9
TFC-6-8RP	3/8	9.52	G 1/2	0.28	7.11	1-1/16	27.0	1.58	40.17	1.68	42.71	0.66	16.9
TFC-8-8RP	1/2	12.70	G 1/2	0.41	10.41	1-1/16	27.0	1.58	40.17	1.98	50.33	0.90	22.9
TFC-8-12RP	1/2	12.70	G 3/4	0.41	10.41	1-5/16	33.3	1.64	41.70	2.04	51.86	0.90	22.9
TFC-12-12RP	3/4	19.05	G 3/4	0.62	15.74	1-5/16	33.3	1.64	41.70	2.04	51.86	0.96	24.5
TFC-16-16RP	1	25.40	G 1	0.88	22.35	1-3/8	41.3	2.03	51.63	2.51	63.83	1.23	31.2

"D" - Dimension is minimum opening - dimensions are for reference only, and are subject to change without notice.

TUBE FITTINGS |

FEMALE CONNECTOR (GAUGE CONNECTOR)

TFC

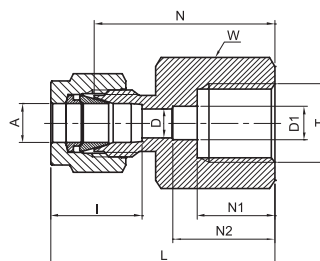

TUBE (METRIC) TO FEMALE ISO PARALLEL THREAD													
Part Number	A Tube O.D.		T ISO	D	D1		W Hex. flat	N	N1	N2		L	I
	mm	in	in	mm	mm	mm	mm	mm	mm	mm	mm	mm	mm
TFC - 3M - 4RG	3		G 1/4	2.4	0.22	5.5	19	28.7	13	0.67	17.0	35.3	12.9
TFC - 6M - 4RG	6		G 1/4	4.8	0.22	5.5	19	30.2	13	0.67	17.0	37.6	15.3
TFC - 6M - 6RG	6		G 3/8	4.8	0.26	6.5	24	30.2	16	0.80	20.3	37.6	15.3
TFC - 6M - 8RG	6		G 1/2	4.8	0.28	7.0	27	36.3	19	0.98	24.9	43.0	15.3
TFC - 8M - 4RG	8		G 1/4	5.5	-	-	19	31.0	13	-	-	38.5	16.2
TFC - 8M - 6RG	8		G 3/8	6.5	-	-	24	28.7	16	-	-	36.2	16.2
TFC - 8M - 8RG	8		G 1/2	7.0	-	-	27	33.0	19	-	-	40.5	16.2
TFC - 10M - 4RG	10		G 1/4	5.5	-	-	19	31.8	13	-	-	39.4	17.2
TFC - 10M - 6RG	10		G 3/8	6.5	-	-	24	31.2	16	-	-	38.8	17.2
TFC - 10M - 8RG	10		G 1/2	7.0	-	-	27	34.5	19	-	-	41.4	17.2
TFC - 12M - 4RG	12		G 1/4	5.5	-	-	22	31.8	13	-	-	41.9	22.8
TFC - 12M - 6RG	12		G 3/8	6.5	-	-	24	34.3	16	-	-	44.4	22.8
TFC - 12M - 8RG	12		G 1/2	7.0	-	-	27	38.1	19	-	-	48.2	22.8
TFC - 20M - 8RG	20		G 1/2	7.0	-	-	30	44.2	19	-	-	54.3	26.0
TFC - 22M - 8RG	22		G 1/2	7.0	-	-	30	44.2	19	-	-	54.3	26.0

TUBE (INCH) TO FEMALE ISO PARALLEL THREAD																			
Part Number	A Tube O.D.		T ISO	D		D1		W Hex. flat		N		N1		N2		L		I	
	in	mm	in	in	mm	in	mm	in	mm	in	mm	in	mm	in	mm	in	mm	in	mm
TFC - 4 - 4RG	1/4	6.35	G 1/4	0.19	4.82	0.22	5.5	3/4	19.1	1.19	30.22	0.51	13	0.67	17.0	1.48	37.59	0.60	15.3
TFC - 4 - 6RG	1/4	6.35	G 3/8	0.19	4.82	0.26	6.5	15/16	23.8	1.19	30.22	0.63	16	0.80	20.3	1.48	37.59	0.60	15.3
TFC - 4 - 8RG	1/4	6.35	G 1/2	0.19	4.82	0.28	7.0	1-1/16	27.0	1.18	30.07	0.75	19	0.98	24.9	1.71	43.43	0.60	15.3
TFC - 5 - 4RG	5/16	7.93	G 1/4	0.22	5.5	-	-	3/4	19.1	1.22	30.98	0.51	13	-	-	1.51	38.35	0.64	16.3
TFC - 5 - 8RG	5/16	7.93	G 1/2	0.28	7.0	-	-	1-1/16	27.0	1.30	33.02	0.75	19	-	-	1.59	40.38	0.64	16.3
TFC - 6 - 4RG	3/8	9.52	G 1/4	0.22	5.5	-	-	3/4	19.1	1.25	31.75	0.51	13	-	-	1.54	39.12	0.66	16.9
TFC - 6 - 6RG	3/8	9.52	G 3/8	0.26	6.5	-	-	15/16	23.8	1.23	31.24	0.63	16	-	-	1.52	38.61	0.66	16.9
TFC - 6 - 8RG	3/8	9.52	G 1/2	0.28	7.0	-	-	1-1/16	27.0	1.36	34.54	0.75	19	-	-	1.65	41.91	0.66	16.9
TFC - 8 - 4RG	1/2	12.7	G 1/4	0.22	5.5	-	-	7/8	22.2	1.25	31.8	0.51	13	-	-	1.65	41.95	0.9	22.9
TFC - 8 - 6RG	1/2	12.7	G 3/8	0.26	6.5	-	-	15/16	23.8	1.35	34.29	0.63	16	-	-	1.75	44.45	0.9	22.9
TFC - 8 - 8RG	1/2	12.7	G 1/2	0.28	7.0	-	-	1-1/16	27.0	1.50	38.10	0.75	19	-	-	1.90	48.26	0.9	22.9

"D" - Dimension is minimum opening - dimensions are for reference only, and are subject to change without notice.

REDUCER

TR

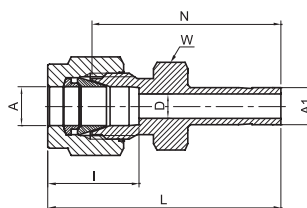

TUBE (METRIC) TO STUB (METRIC)							
Part Number	A	A1	D	W	N	L	i
	Tube O.D.	Tube O.D.		Hex. flat			
	mm	mm	mm	mm	mm	mm	mm
TR - 2M - 3M	2	3	1.7	12	26.9	33.5	12.9
TR - 3M - 4M	3	4	2.4	12	28.4	35.0	12.9
TR - 3M - 6M	3	6	2.4	12	29.5	36.1	12.9
TR - 3M - 10M	3	10	2.4	14	31.8	38.4	12.9
TR - 4M - 6M	4	6	2.4	12	30.5	37.1	13.7
TR - 6M - 3M	6	3	1.8	14	29.5	36.9	15.3
TR - 6M - 8M	6	8	4.8	14	32.5	39.9	15.3
TR - 6M - 10M	6	10	4.8	14	33.3	40.7	15.3
TR - 6M - 12M	6	12	4.8	14	38.9	46.3	15.3
TR - 6M - 18M	6	18	4.8	22	42.2	49.6	15.3
TR - 8M - 6M	8	6	4.0	15	32.8	40.3	16.2
TR - 8M - 10M	8	10	6.4	15	34.5	42.0	16.2
TR - 8M - 12M	8	12	6.4	15	40.1	47.6	16.2
TR - 10M - 6M	10	6	4.0	18	34.8	42.4	17.2
TR - 10M - 8M	10	8	5.6	18	35.8	43.4	17.2
TR - 10M - 12M	10	12	7.9	18	42.2	49.8	17.2
TR - 10M - 15M	10	15	7.9	18	43.7	51.3	17.2
TR - 10M - 18M	10	18	7.9	22	43.7	51.3	17.2
TR - 12M - 6M	12	6	4.0	22	34.8	44.9	22.8
TR - 12M - 10M	12	10	7.7	22	36.6	46.7	22.8
TR - 12M - 16M	12	16	9.5	22	43.7	53.8	22.8
TR - 12M - 18M	12	18	9.5	22	43.7	53.8	22.8
TR - 12M - 20M	12	20	9.5	22	46.0	56.1	22.8
TR - 12M - 22M	12	22	9.5	24	46.0	46.1	22.8
TR - 12M - 25M	12	25	9.5	27	52.3	62.4	22.8
TR - 16M - 12M	16	12	9.1	24	42.9	53.0	24.4
TR - 18M - 12M	18	12	9.1	27	44.5	54.6	24.4
TR - 18M - 16M	18	16	12.7	27	46.0	56.1	24.4
TR - 18M - 20M	18	20	15.1	27	47.5	57.6	24.4
TR - 18M - 22M	18	22	15.1	27	47.5	57.6	24.4
TR - 18M - 25M	18	25	15.1	27	52.3	62.4	24.4
TR - 20M - 16M	20	16	12.7	30	47.8	57.9	26.0
TR - 20M - 18M	20	18	13.9	30	47.8	57.9	26.0
TR - 20M - 22M	20	22	15.8	30	49.3	59.4	26.0
TR - 20M - 25M	20	25	15.9	30	54.1	64.2	26.0
TR - 22M - 18M	22	18	13.9	30	47.8	57.9	26.0
TR - 22M - 20M	22	20	15.1	30	49.3	59.4	26.0
TR - 22M - 25M	22	25	18.3	30	54.1	64.2	26.0
TR - 25M - 18M	25	18	13.9	35	50.8	63.1	31.3
TR - 25M - 20M	25	20	15.1	35	52.3	64.6	31.3

"D" - Dimension is minimum opening - dimensions are for reference only, and are subject to change without notice.

REDUCER

TR

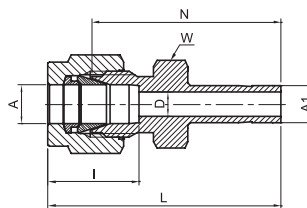

TUBE (METRIC) TO STUB (INCH)

Part Number	A Tube O.D.	A1 Tube O.D.	D	W Hex. flat	N	L	i
	mm	in	mm	mm	mm	mm	mm
TR - 2M - 2	2	1/8	1.7	12	26.9	33.5	12.9
TR - 3M - 2	3	1/8	2.0	12	26.9	33.5	12.9
TR - 3M - 4	3	1/4	2.4	12	29.5	36.1	12.9
TR - 4M - 4	4	1/4	2.4	12	30.5	37.1	13.7
TR - 6M - 2	6	1/8	2.2	14	29.5	36.9	15.3
TR - 6M - 5	6	5/16	4.8	14	32.5	39.9	15.3
TR - 6M - 6	6	3/8	4.8	14	33.3	40.7	15.3
TR - 6M - 8	6	1/2	4.8	14	38.9	46.3	15.3
TR - 8M - 6	8	3/8	6.4	15	34.5	42.0	16.2
TR - 8M - 8	8	1/2	6.4	15	40.1	47.6	16.2
TR - 10M - 6	10	3/8	7.1	18	36.6	44.2	17.2
TR - 10M - 8	10	1/2	7.9	18	42.2	49.8	17.2
TR - 12M - 8	12	1/2	9.5	22	42.2	52.3	22.8
TR - 12M - 12	12	3/4	9.5	22	43.7	53.8	22.8
TR - 18M - 12	18	3/4	15.1	27	46.0	56.1	24.4
TR - 18M - 16	18	1	15.1	27	52.3	62.4	24.4
TR - 25M - 16	25	1	20.2	35	57.2	69.4	31.3

"D" - Dimension is minimum opening - dimensions are for reference only, and are subject to change without notice.

REDUCER

TR

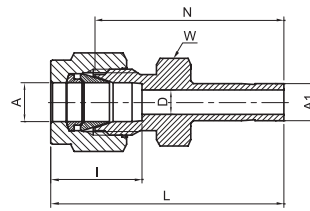

TUBE (INCH) TO STUB (INCH)														
Part Number	A Tube O.D.		A1 Tube O.D.		D		W Hex. flat		N		L		I	
	in	mm	in	mm	in	mm	in	mm	in	mm	in	mm	in	mm
TR - 1 - 2	1/16	1.58	1/8	3.17	0.05	1.27	5/16	7.9	1.00	25.40	1.15	29.21	0.34	8.6
TR - 1 - 4	1/16	1.58	1/4	6.35	0.05	1.27	5/16	7.9	1.09	27.68	1.24	31.50	0.34	8.6
TR - 2 - 1	1/8	3.17	1/16	1.58	0.03	0.76	7/16	11.1	0.88	22.35	1.14	28.96	0.50	12.7
TR - 2 - 3	1/8	3.17	3/16	4.76	0.09	2.28	7/16	11.1	1.09	27.68	1.35	34.29	0.50	12.7
TR - 2 - 4	1/8	3.17	1/4	6.35	0.09	2.28	7/16	11.1	1.16	29.46	1.42	36.06	0.50	12.7
TR - 2 - 6	1/8	3.17	3/8	9.52	0.09	2.28	7/16	11.1	1.22	30.98	1.48	37.59	0.50	12.7
TR - 2 - 8	1/8	3.17	1/2	12.70	0.09	2.28	9/16	14.3	1.48	37.59	1.74	44.20	0.50	12.7
TR - 3 - 2	3/16	4.76	1/8	3.17	0.08	2.03	7/16	11.1	1.11	28.19	1.37	34.80	0.54	13.7
TR - 3 - 4	3/16	4.76	1/4	6.35	0.12	3.04	7/16	11.1	1.20	30.48	1.46	37.08	0.60	15.3
TR - 4 - 2	1/4	6.35	1/8	3.17	0.08	2.03	1/2	12.7	1.16	29.46	1.45	36.83	0.60	15.3
TR - 4 - 3	1/4	6.35	3/16	4.76	0.12	3.04	1/2	12.7	1.19	30.22	1.48	37.59	0.60	15.3
TR - 4 - 4	1/4	6.35	1/4	6.35	0.17	4.20	1/2	12.7	1.25	31.75	1.54	39.11	0.60	15.3
TR - 4 - 5	1/4	6.35	5/16	7.93	0.19	4.82	1/2	12.7	1.28	32.51	1.57	39.87	0.60	15.3
TR - 4 - 6	1/4	6.35	3/8	9.52	0.19	4.82	1/2	12.7	1.31	33.27	1.60	40.64	0.60	15.3
TR - 4 - 8	1/4	6.35	1/2	12.70	0.19	4.82	9/16	14.3	1.53	38.86	1.82	46.22	0.60	15.3
TR - 4 - 10	1/4	6.35	5/8	7.93	0.19	4.82	11/16	17.5	1.60	40.64	1.89	48.00	0.60	15.3
TR - 4 - 12	1/4	6.35	3/4	19.05	0.19	4.82	13/16	20.6	1.59	40.39	1.88	47.75	0.60	15.3
TR - 5 - 6	5/16	7.93	3/8	9.52	0.25	6.35	9/16	14.3	1.36	34.54	1.65	41.91	0.64	16.3
TR - 5 - 8	5/16	7.93	1/2	12.70	0.25	6.35	9/16	14.3	1.58	40.13	1.87	47.49	0.64	16.3
TR - 6 - 4	3/8	9.52	1/4	6.35	0.17	4.20	5/8	15.9	1.34	34.03	1.63	41.40	0.66	16.9
TR - 6 - 6	3/8	9.52	3/8	9.52	0.28	7.11	5/8	15.9	1.41	35.81	1.70	43.18	0.66	16.9
TR - 6 - 8	3/8	9.52	1/2	12.70	0.28	7.11	5/8	15.9	1.62	41.14	1.91	48.51	0.66	16.9
TR - 6 - 10	3/8	9.52	5/8	15.87	0.28	7.11	11/16	17.5	1.69	42.92	1.98	50.29	0.66	16.9
TR - 6 - 12	3/8	9.52	3/4	19.05	0.28	7.11	13/16	20.6	1.69	42.92	1.98	50.29	0.66	16.9
TR - 8 - 4	1/2	12.70	1/4	6.35	0.19	4.82	13/16	20.6	1.37	34.80	1.77	44.96	0.90	22.9
TR - 8 - 6	1/2	12.70	3/8	9.52	0.28	7.11	13/16	20.6	1.44	36.58	1.84	46.74	0.90	22.9
TR - 8 - 8	1/2	12.70	1/2	12.70	0.39	9.91	13/16	20.6	1.66	42.16	2.06	52.32	0.90	22.9
TR - 8 - 10	1/2	12.70	5/8	15.87	0.41	10.41	13/16	20.6	1.72	43.68	2.12	53.84	0.90	22.9
TR - 8 - 12	1/2	12.70	3/4	19.05	0.41	10.41	13/16	20.6	1.72	43.68	2.12	53.84	0.90	22.9
TR - 8 - 16	1/2	12.70	1	25.40	0.41	10.41	1-1/16	27.0	1.97	50.03	2.37	60.19	0.90	22.9
TR - 10 - 12	5/8	15.87	3/4	19.05	0.50	12.70	1-5/16	23.8	1.75	44.45	2.15	54.61	0.96	24.4
TR - 10 - 14	5/8	15.87	7/8	22.22	0.50	12.70	1-5/16	23.8	1.81	45.97	2.21	56.13	0.96	24.4
TR - 10 - 16	5/8	15.87	1	25.40	0.50	12.70	1-1/16	27.0	2.00	50.80	2.40	60.96	0.96	24.4
TR - 12 - 8	3/4	19.05	1/2	12.70	0.39	9.91	1-1/16	27.0	1.75	44.45	2.15	54.61	0.96	24.5
TR - 12 - 16	3/4	19.05	1	25.40	0.62	15.75	1-1/16	27.0	2.06	52.32	2.46	62.48	0.96	24.5
TR - 16 - 20	1	25.40	1-1/4	31.75	0.88	22.35	1-3/8	34.9	2.69	68.33	3.17	80.52	1.23	31.2
TR - 16 - 24	1	25.40	1-1/2	38.10	0.88	22.35	1-5/8	41.3	3.03	76.96	3.51	89.15	1.23	31.2
TR - 20 - 24	1-1/4	31.75	1-1/2	38.10	1.09	27.70	1-3/4	44.5	3.23	82.00	4.10	104.1	1.62	41.2

"D" - Dimension is minimum opening - dimensions are for reference only, and are subject to change without notice.

TUBE FITTINGS |

REDUCING PORT CONNECTOR

TRPC

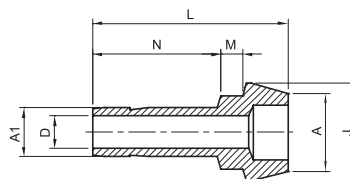

CONNECTS TWO T-LOK PORTS (METRIC)										
Part Number	A Tube O.D.		D	N		L		J		M
	mm	mm		mm	mm	mm	mm	mm	mm	
TRPC - 6M - 3M	6	3	2.1	13.5	22.9	9.0	3.2			
TRPC - 8M - 6M	8	6	4.0	15.7	24.7	11.0	3.1			
TRPC - 10M - 6M	10	6	4.0	15.7	25.8	13.1	3.4			
TRPC - 10M - 8M	10	8	5.6	16.8	26.1	13.1	3.1			
TRPC - 12M - 6M	12	6	4.0	15.7	29.1	15.0	3.6			
TRPC - 12M - 8M	12	8	5.6	16.8	30.1	15.0	3.4			
TRPC - 12M - 10M	12	10	7.1	17.5	30.6	15.0	3.1			
TRPC - 16M - 10M	16	10	8.8	23.1	37.5	19.0	3.4			

CONNECTS TWO T-LOK PORTS (INCH)														
Part Number	A Tube O.D.		A1 Tube O.D.		D		N		L		J		M	
	in	mm	in	mm	in	mm	in	mm	in	mm	in	mm	in	mm
TRPC - 2 - 1	1/8	3.17	1/16	1.58	0.03	0.75	0.36	9.14	0.72	18.3	0.24	6.15	0.10	2.56
TRPC - 4 - 1	1/4	6.35	1/16	1.58	0.03	0.75	0.36	9.14	0.75	19.05	0.37	9.40	0.15	3.81
TRPC - 4 - 2	1/4	6.35	1/8	3.17	0.09	2.20	0.54	13.71	0.90	22.86	0.37	9.40	0.12	3.05
TRPC - 6 - 2	3/8	9.52	1/8	3.17	0.09	2.20	0.54	13.71	0.92	23.37	0.50	12.7	0.15	3.76
TRPC - 6 - 4	3/8	9.52	1/4	6.35	0.17	4.20	0.64	16.26	1.00	25.4	0.50	12.7	0.13	3.24
TRPC - 8 - 4	1/2	12.70	1/4	6.35	0.17	4.20	0.64	16.26	1.17	29.72	0.62	15.8	0.14	3.66
TRPC - 8 - 6	1/2	12.70	3/8	9.52	0.27	6.85	0.70	17.78	1.21	30.73	0.62	15.8	0.12	3.15
TRPC - 12 - 8	3/4	19.05	1/2	12.70	0.37	9.40	0.96	24.38	1.49	37.85	0.87	22.1	0.15	3.87

Reducing port connector TRPC

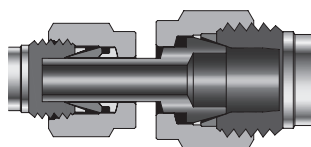

"D" - Dimension is minimum opening - dimensions are for reference only, and are subject to change without notice.

PORT CONNECTOR

TPC

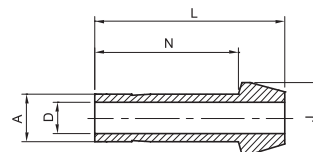

CONNECTS TWO T-LOK PORTS (METRIC)										
Part Number	A Tube O.D.		D		N		L		J	
	mm	in	mm	in	mm	in	mm	in	mm	in
TPC - 3M	3	0.118	2.1	0.083	15.7	0.618	22.2	0.874	6.0	0.236
TPC - 6M	6	0.236	4.0	0.157	18.7	0.736	25.0	0.984	9.0	0.354
TPC - 8M	8	0.315	6.0	0.236	20.0	0.787	25.9	1.016	11.0	0.433
TPC - 10M	10	0.394	7.1	0.279	20.2	0.799	27.1	1.067	13.1	0.515
TPC - 12M	12	0.472	8.8	0.346	26.0	1.024	36.2	1.421	15.0	0.591
TPC - 16M	16	0.630	12.7	0.500	27.6	1.087	37.4	1.472	19.0	0.748
TPC - 18M	18	0.709	13.9	0.547	27.6	1.087	37.4	1.472	21.1	0.831

CONNECTS TWO T-LOK PORTS (INCH)										
Part Number	A Tube O.D.		D		N		L		J	
	in	mm	in	mm	in	mm	in	mm	in	mm
TPC - 1	1/16	1.58	0.03	0.75	0.42	10.72	0.54	13.72	0.13	3.30
TPC - 2	1/8	3.17	0.09	2.20	0.62	15.75	0.88	22.35	0.24	6.15
TPC - 4	1/4	6.35	0.17	4.20	0.74	18.80	0.98	24.9	0.37	9.40
TPC - 5	5/16	7.93	0.24	6.00	0.79	20.11	1.02	25.91	0.43	11.00
TPC - 6	3/8	9.52	0.27	6.85	0.82	20.77	1.05	26.67	0.50	12.70
TPC - 8	1/2	12.70	0.37	9.40	1.04	26.52	1.43	36.32	0.62	15.80
TPC - 12	3/4	19.05	0.59	15.00	1.11	28.25	1.49	37.85	0.87	22.10
TPC - 16	1	25.40	0.80	20.30	1.40	35.68	1.94	49.28	1.12	28.50

Port connector TPC

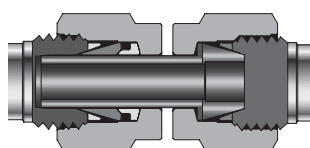

"D"- Dimension is minimum opening - dimensions are for reference only, and are subject to change without notice.
 For 1/16, 1/8 and 3/16 in 2, 3 and 4mm tube fittings, tighten the port connector 1/8 turn.
 For over 1 in and over 25mm tube fittings, tighten the port connector 1/4 turn.

MALE CONNECTOR

TMC-N

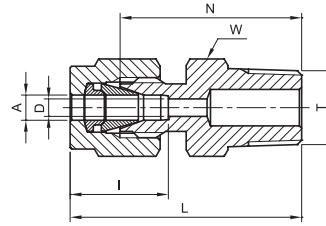

TUBE (METRIC) MALE NPT THREAD

Part Number	A	T	D	W	N	L	I
	Tube O.D.	NPT		Hex. flat			
	mm	in	mm	mm	mm	mm	mm
TMC - 3M - 2N	3	1/8	2.4	12	23.9	30.5	12.9
TMC - 3M - 4N	3	1/4	2.4	14	29.0	35.6	12.9
TMC - 4M - 2N	4	1/8	2.4	14	24.6	31.2	13.7
TMC - 4M - 4N	4	1/4	2.4	14	29.7	36.3	13.7
TMC - 6M - 2N	6	1/8	4.8	14	25.4	32.8	15.3
TMC - 6M - 4N	6	1/4	4.8	14	30.5	37.9	15.3
TMC - 6M - 6N	6	3/8	4.8	18	31.0	38.4	15.3
TMC - 6M - 8N	6	1/2	4.8	22	37.3	44.7	15.3
TMC - 8M - 2N	8	1/8	4.8	15	26.7	34.2	16.2
TMC - 8M - 4N	8	1/4	6.4	15	31.2	38.7	16.2
TMC - 8M - 6N	8	3/8	6.4	18	31.8	39.3	16.2
TMC - 8M - 8N	8	1/2	6.4	22	38.1	45.6	16.2
TMC - 10M - 2N	10	1/8	4.8	18	28.7	36.3	17.2
TMC - 10M - 4N	10	1/4	7.9	18	33.3	40.9	17.2
TMC - 10M - 6N	10	3/8	7.9	18	33.3	40.9	17.2
TMC - 10M - 8N	10	1/2	7.9	22	38.9	46.5	17.2
TMC - 10M - 12N	10	3/4	7.9	27	40.4	48.0	17.2
TMC - 12M - 2N	12	1/8	4.8	22	28.7	38.3	22.8
TMC - 12M - 4N	12	1/4	7.1	22	33.3	43.4	22.8
TMC - 12M - 6N	12	3/8	9.5	22	33.3	43.4	22.8
TMC - 12M - 8N	12	1/2	9.5	22	38.9	49.0	22.8
TMC - 12M - 12N	12	3/4	9.5	27	40.4	50.5	22.8
TMC - 14M - 4N	14	1/4	7.1	24	34.0	44.1	24.4
TMC - 14M - 6N	14	3/8	9.5	24	34.0	44.1	24.4
TMC - 14M - 8N	14	1/2	11.1	24	38.9	49.0	24.4
TMC - 15M - 8N	15	1/2	11.9	24	38.9	49.0	24.4
TMC - 16M - 6N	16	3/8	9.5	24	34.0	44.1	24.4
TMC - 16M - 8N	16	1/2	11.9	24	38.9	49.0	24.4
TMC - 16M - 12N	16	3/4	12.7	27	40.4	50.5	24.4
TMC - 18M - 8N	18	1/2	11.9	27	40.4	50.5	24.4
TMC - 18M - 12N	18	3/4	15.1	27	40.4	50.5	24.4
TMC - 20M - 8N	20	1/2	11.9	30	42.2	52.3	26.0
TMC - 20M - 12N	20	3/4	15.9	30	42.2	52.3	26.0
TMC - 22M - 12N	22	3/4	15.9	30	42.2	52.3	26.0
TMC - 22M - 16N	22	1	18.3	35	47.0	57.1	26.0
TMC - 25M - 8N	25	1/2	11.9	35	45.2	57.5	31.3
TMC - 25M - 12N	25	3/4	15.9	35	45.2	57.5	31.3
TMC - 25M - 16N	25	1	21.8	35	50	62.3	31.3
TMC - 28M - 16N	28	1	21.8	41	51.6	72.4	36.6
TMC - 28M - 20N	28	1-1/4	21.8	46	52.3	73.1	36.6
TMC - 32M - 20N	32	1-1/4	28.6	46	56.6	79.6	42.0
TMC - 32M - 24N	38	1-1/2	33.7	50	58.1	91.6	49.4

For inches, see next page

"D" - Dimension is minimum opening - dimensions are for reference only, and are subject to change without notice.

MALE CONNECTOR

TMC-N

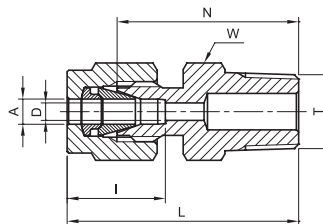

TUBE (INCH) MALE NPT THREAD													
Part Number	A Tube O.D.		T NPT	D		W Hex. flat		N		L		I	
	in	mm	in	in	mm	in	mm	in	mm	in	mm	in	mm
TMC - 1 - 1N	1/16	1.58	1/16	0.05	1.27	5/16	7.9	0.79	20	0.94	23.83	0.34	8.6
TMC - 1 - 2N	1/16	1.58	1/8	0.05	1.27	7/16	11.1	0.88	22.35	1.03	26.10	0.34	8.6
TMC - 1 - 4N	1/16	1.58	1/4	0.05	1.27	9/16	14.3	1.07	27.17	1.22	30.98	0.34	8.6
TMC - 2 - 1N	1/8	3.17	1/16	0.09	2.28	7/16	11.1	0.91	23.11	1.17	29.71	0.50	12.7
TMC - 2 - 2N	1/8	3.17	1/8	0.09	2.28	7/16	11.1	0.94	23.90	1.20	30.48	0.50	12.7
TMC - 2 - 4N	1/8	3.17	1/4	0.09	2.28	9/16	14.3	1.14	28.95	1.40	35.56	0.50	12.7
TMC - 2 - 6N	1/8	3.17	3/8	0.09	2.28	11/16	17.5	1.15	29.21	1.41	35.81	0.50	12.7
TMC - 2 - 8N	1/8	3.17	1/2	0.09	2.28	7/8	22.2	1.40	35.56	1.66	42.16	0.50	12.7
TMC - 3 - 2N	3/16	4.76	1/8	0.12	3.04	7/16	11.1	0.97	24.63	1.23	31.24	0.54	13.7
TMC - 3 - 4N	3/16	4.76	1/4	0.12	3.04	9/16	14.3	1.17	29.72	1.43	36.32	0.54	13.7
TMC - 4 - 1N	1/4	6.35	1/16	0.19	4.82	1/2	12.7	1.00	25.4	1.29	32.76	0.60	15.3
TMC - 4 - 2N	1/4	6.35	1/8	0.19	4.82	1/2	12.7	1.00	25.40	1.29	32.76	0.60	15.3
TMC - 4 - 4N	1/4	6.35	1/4	0.19	4.82	9/16	14.3	1.20	30.50	1.49	37.85	0.60	15.3
TMC - 4 - 6N	1/4	6.35	3/8	0.19	4.82	11/16	17.5	1.22	31.00	1.51	38.35	0.60	15.3
TMC - 4 - 8N	1/4	6.35	1/2	0.19	4.82	7/8	22.2	1.47	37.34	1.76	44.70	0.60	15.3
TMC - 4 - 12N	1/4	6.35	3/4	0.19	4.82	1-1/16	27	1.53	38.86	1.82	46.22	0.60	15.3
TMC - 5 - 2N	5/16	7.93	1/8	0.19	4.82	9/16	14.3	1.05	26.67	1.34	34.03	0.64	16.2
TMC - 5 - 4N	5/16	7.93	1/4	0.25	6.35	9/16	14.3	1.23	31.24	1.52	38.60	0.64	16.2
TMC - 5 - 6N	5/17	7.93	3/8	0.25	6.35	11/16	17.5	1.25	31.75	1.54	39.11	0.64	16.2
TMC - 6 - 2N	3/8	9.52	1/8	0.19	4.82	5/8	15.9	1.10	27.90	1.39	35.30	0.66	16.9
TMC - 6 - 4N	3/8	9.52	1/4	0.28	7.11	5/8	15.9	1.28	32.51	1.57	39.87	0.66	16.9
TMC - 6 - 6N	3/8	9.52	3/8	0.28	7.11	11/16	17.5	1.28	32.51	1.57	39.87	0.66	16.9
TMC - 6 - 8N	3/8	9.52	1/2	0.28	7.11	7/8	22.2	1.52	38.90	1.82	46.23	0.66	16.9
TMC - 6 - 12N	3/8	9.52	3/4	0.28	7.11	1-1/16	27.0	1.59	40.38	1.88	47.75	0.66	16.9
TMC - 8 - 2N	1/2	12.70	1/8	0.19	4.82	13/16	20.6	1.13	28.70	1.53	38.86	0.90	22.9
TMC - 8 - 4N	1/2	12.70	1/4	0.28	7.11	13/16	20.6	1.31	33.27	1.71	43.43	0.90	22.9
TMC - 8 - 6N	1/2	12.70	3/8	0.38	9.65	13/16	20.6	1.31	33.27	1.71	43.43	0.90	22.9
TMC - 8 - 8N	1/2	12.70	1/2	0.41	10.41	7/8	22.2	1.53	38.90	1.93	49.02	0.90	22.9
TMC - 8 - 12N	1/2	12.70	3/4	0.41	10.41	1-1/16	27.0	1.59	40.38	1.99	50.54	0.90	22.9
TMC - 8 - 16N	1/2	12.70	1	0.41	10.41	1-3/8	34.9	1.85	47.00	2.25	57.15	0.90	22.9
TMC - 10 - 6N	5/8	15.87	3/8	0.38	9.65	15/16	23.8	1.34	34.03	1.74	44.19	0.96	24.4
TMC - 10 - 8N	5/8	15.87	1/2	0.47	11.90	15/16	23.8	1.53	38.86	1.93	49.02	0.96	24.4
TMC - 10 - 12N	5/8	15.87	3/4	0.50	12.70	1-1/16	27.0	1.59	40.38	1.99	50.54	0.96	24.4
TMC - 12 - 8N	3/4	19.05	1/2	0.50	12.70	1-1/16	27.0	1.59	40.38	1.99	50.54	0.96	24.5
TMC - 12 - 12N	3/4	19.05	3/4	0.62	15.74	1-1/16	27.0	1.59	40.38	1.99	50.54	0.96	24.5
TMC - 12 - 16N	3/4	19.05	1	0.62	15.74	1-3/8	34.9	1.85	47.00	2.25	57.15	0.96	24.5
TMC - 14 - 12N	7/8	22.22	3/4	0.72	18.28	1-3/16	30.2	1.59	40.38	1.99	50.54	1.02	25.9
TMC - 14 - 16N	7/8	22.22	1	0.72	18.28	1-3/8	34.9	1.85	46.99	2.25	57.15	1.02	25.9
TMC - 16 - 8N	1	25.4	1/2	0.47	11.90	1-3/8	34.9	1.78	45.21	2.26	57.4	1.23	31.2
TMC - 16 - 12N	1	25.40	3/4	0.72	18.28	1-3/8	34.9	1.78	45.21	2.26	57.40	1.23	31.2
TMC - 16 - 16N	1	25.40	1	0.88	22.30	1-3/8	34.9	1.97	50.03	2.45	62.23	1.23	31.2
TMC - 20 - 16N	1-1/4	31.75	1	0.86	21.80	1-3/4	44.5	2.17	55.12	3.04	77.22	1.62	41.2
TMC - 20 - 20N	1-1/4	31.75	1-1/4	1.09	27.70	1-3/4	44.5	2.17	55.12	3.04	77.22	1.62	41.2
TMC - 24 - 24N	1-1/2	38.10	1-1/2	1.34	34.00	2-1/8	54.0	2.43	61.72	3.50	88.90	1.97	50.0
TMC - 32 - 32N	2	50.80	2	1.81	45.97	2-3/4	69.9	3.00	76.20	4.47	113.54	2.66	67.6

Reference Specifications :

- 60° thread angle
- Pitch measured in inches
- Truncation of root and crest are flat
- Taper angel 1° 47'

American Standard Pipe Thread NPT.

NPT (National Pipe Tapered) is made to specifications outlined in ANSI B1.20.1.

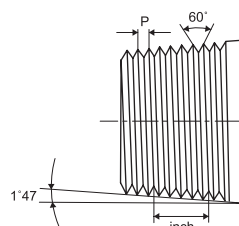

"D" - Dimension is minimum opening - dimensions are for reference only, and are subject to change without notice.

MALE CONNECTOR

TMC-P

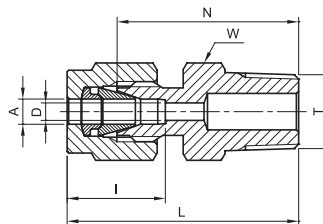

TUBE (METRIC) ISO TAPERED THREAD

Part Number	A Tube O.D.	T ISO	D	W Hex. flat	N	L	I
	mm	in	mm	mm	mm	mm	mm
TMC - 2M - 2P	2	R 1/8	1.7	12	23.9	30.5	12.9
TMC - 3M - 2P	3	R 1/8	2.4	12	23.9	30.5	12.9
TMC - 3M - 4P	3	R 1/4	2.4	14	29.0	35.6	12.9
TMC - 4M - 2P	4	R 1/8	2.4	12	24.6	31.2	13.7
TMC - 4M - 4P	4	R 1/4	2.4	14	29.7	36.3	13.7
TMC - 6M - 2P	6	R 1/8	4.8	14	25.4	32.8	15.3
TMC - 6M - 4P	6	R 1/4	4.8	14	30.5	37.9	15.3
TMC - 6M - 6P	6	R 3/8	4.8	18	31.0	38.4	15.3
TMC - 6M - 8P	6	R 1/2	4.8	22	37.3	44.7	15.3
TMC - 8M - 2P	8	R 1/8	4.8	15	26.7	34.2	16.2
TMC - 8M - 4P	8	R 1/4	6.4	15	31.2	38.7	16.2
TMC - 8M - 6P	8	R 3/8	6.4	18	31.8	39.2	16.2
TMC - 8M - 8P	8	R 1/2	6.4	22	38.1	45.6	16.2
TMC - 10M - 2P	10	R 1/8	4.8	18	28.7	36.3	17.2
TMC - 10M - 4P	10	R 1/4	7.9	18	33.3	40.9	17.2
TMC - 10M - 6P	10	R 3/8	7.9	18	33.3	40.9	17.2
TMC - 10M - 8P	10	R 1/2	7.9	22	38.9	46.5	17.2
TMC - 12M - 4P	12	R 1/4	7.1	22	33.3	43.4	22.8
TMC - 12M - 6P	12	R 3/8	9.5	22	33.3	43.4	22.8
TMC - 12M - 8P	12	R 1/2	9.5	22	38.9	49.0	22.8
TMC - 12M - 12P	12	R 3/4	9.5	27	40.4	50.5	22.8
TMC - 15M - 8P	15	R 1/2	11.9	24	38.9	49.0	24.4
TMC - 16M - 4P	16	R 1/4	7.1	24	34.0	44.1	24.4
TMC - 16M - 6P	16	R 3/8	9.5	24	34.0	44.1	24.4
TMC - 16M - 8P	16	R 1/2	11.9	24	38.9	49.0	24.4
TMC - 16M - 12P	16	R 3/4	12.7	27	40.4	50.5	24.4
TMC - 18M - 8P	18	R 1/2	11.9	27	40.4	50.5	24.4
TMC - 18M - 12P	18	R 3/4	15.1	27	40.4	50.5	24.4
TMC - 20M - 8P	20	R 1/2	11.9	30	42.2	52.3	26.0
TMC - 20M - 12P	20	R 3/4	15.9	30	42.2	52.3	26.0
TMC - 22M - 12P	22	R 3/4	15.9	30	42.2	52.3	26.0
TMC - 22M - 16P	22	R 1	18.3	35	47.0	57.1	26.0
TMC - 25M - 12P	25	R 3/4	15.9	35	45.2	57.5	31.3
TMC - 25M - 16P	25	R 1	21.8	35	50.0	62.3	31.3
TMC - 28M - 16P	28	R 1	21.8	41	51.6	72.4	36.6
TMC - 28M - 20P	28	R 1-1/4	21.8	46	52.3	73.1	36.6
TMC - 32M - 20P	32	R 1-1/4	28.6	46	56.6	79.6	42.0
TMC - 32M - 24P	38	R 1-1/2	33.7	50	58.1	91.6	49.4

Reference Specifications :

- DIN - ISO 2999 •55° Thread angle
- BS - 21 •Truncation of root and crest are round
- JIS - B0203 •Taper angle 1° 47'

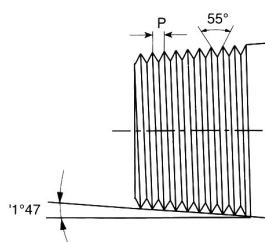

For inches, see next page

"D" - Dimension is minimum opening - dimensions are for reference only, and are subject to change without notice.

MALE CONNECTOR

TMC-P

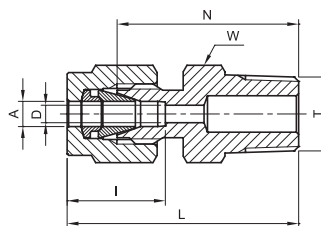

TUBE (INCH) ISO TAPERED THREAD													
Part Number	A Tube O.D.		T ISO	D		W Hex. flat		N		L		I	
	in	mm		in	in	mm	in	mm	in	mm	in	mm	in
TMC - 2 - 2P	1/8	3.17	R 1/8	0.09	2.28	7/16	11.1	0.94	23.90	1.20	30.48	0.50	12.7
TMC - 2 - 4P	1/8	3.17	R 1/4	0.09	2.28	9/16	14.3	1.14	28.95	1.40	35.56	0.50	12.7
TMC - 4 - 2P	1/4	6.35	R 1/8	0.19	4.82	1/2	12.7	1.00	25.40	1.29	32.76	0.60	15.3
TMC - 4 - 4P	1/4	6.35	R 1/4	0.19	4.82	9/16	14.3	1.20	30.50	1.49	37.85	0.60	15.3
TMC - 4 - 6P	1/4	6.35	R 3/8	0.19	4.82	11/16	17.5	1.21	30.78	1.51	38.35	0.60	15.3
TMC - 4 - 8P	1/4	6.35	R 1/2	0.19	4.82	7/8	22.2	1.47	37.34	1.76	44.70	0.60	15.3
TMC - 5 - 2P	5/16	7.93	R 1/8	0.19	4.82	9/16	14.3	1.05	26.67	1.34	34.03	0.64	16.2
TMC - 5 - 4P	5/16	7.93	R 1/4	0.25	6.35	9/16	14.3	1.23	31.24	1.52	38.60	0.64	16.2
TMC - 6 - 2P	3/8	9.52	R 1/8	0.19	4.82	5/8	15.9	1.10	27.90	1.39	35.30	0.66	16.9
TMC - 6 - 4P	3/8	9.52	R 1/4	0.28	7.11	5/8	15.9	1.28	32.51	1.57	39.87	0.66	16.9
TMC - 6 - 6P	3/8	9.52	R 3/8	0.28	7.11	11/16	17.5	1.28	32.51	1.57	39.87	0.66	16.9
TMC - 6 - 8P	3/8	9.52	R 1/2	0.28	7.11	7/8	22.2	1.53	38.90	1.82	46.23	0.66	16.9
TMC - 8 - 4P	1/2	12.70	R 1/4	0.28	7.11	13/16	20.6	1.31	33.27	1.71	43.43	0.90	22.9
TMC - 8 - 6P	1/2	12.70	R 3/8	0.38	9.65	13/16	20.6	1.31	33.27	1.71	43.43	0.90	22.9
TMC - 8 - 8P	1/2	12.70	R 1/2	0.41	10.41	7/8	22.2	1.53	38.90	1.93	49.02	0.90	22.9
TMC - 8 - 12P	1/2	12.70	R 3/4	0.41	10.41	1-1/16	27.0	1.59	40.38	1.99	50.54	0.90	22.9
TMC - 12 - 12P	3/4	19.05	R 3/4	0.62	15.74	1-1/16	27.0	1.59	40.38	1.99	50.54	0.96	24.5
TMC - 16 - 16P	1	25.40	R 1	0.88	22.35	1-3/8	34.9	1.97	50.03	2.45	62.23	1.23	31.2
TMC - 20 - 16P	1-1/4	31.75	R 1	0.86	21.80	1-3/4	44.5	2.17	55.12	3.04	77.22	1.62	41.2
TMC - 20 - 20P	1-1/4	31.75	R 1-1/4	1.09	27.70	1-3/4	44.5	2.17	55.12	3.04	77.22	1.62	41.2
TMC - 24 - 24P	1-1/2	38.10	R 1-1/2	1.34	34.00	2-1/8	54.0	2.43	61.72	3.50	88.90	1.97	50.0
TMC - 32 - 32P	2	50.80	R 2	1.81	45.97	2-3/4	69.9	3.00	76.20	4.47	113.54	2.66	67.6

"D" - Dimension is minimum opening - dimensions are for reference only, and are subject to change without notice.

MALE CONNECTOR

TMC-NTC
THERMOCOUPLE
CONNECTOR

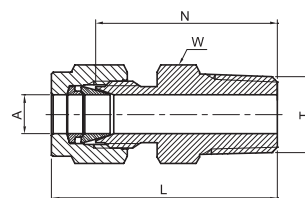

TUBE (INCH) MALE NPT THREAD										
Part Number	A Tube O.D.		T NPT	W Hex. flat		N		L		
	in	mm		in	in	mm	in	mm	in	mm
TMC - 1 - 2NTC	1/16	1.58	1/8	7/16	11.1	0.88	22.35	1.03	26.10	
TMC - 2 - 2NTC	1/8	3.17	1/8	7/16	11.1	0.94	23.90	1.20	30.48	
TMC - 2 - 4NTC	1/8	3.17	1/4	9/16	14.3	1.14	28.95	1.40	35.56	
TMC - 3 - 2NTC	3/16	4.76	1/8	7/16	11.1	0.97	24.53	1.23	36.24	
TMC - 3 - 4NTC	3/16	4.76	1/4	9/16	14.3	1.17	29.72	1.43	36.32	
TMC - 4 - 2NTC	1/4	6.35	1/8	1/2	12.7	1.00	25.40	1.29	32.76	
TMC - 4 - 4NTC	1/4	6.35	1/4	9/16	14.3	1.20	30.50	1.49	37.85	
TMC - 4 - 6NTC	1/4	6.35	3/8	11/16	17.5	1.22	31.00	1.51	38.35	
TMC - 4 - 8NTC	1/4	6.35	1/2	7/8	22.2	1.47	37.34	1.76	44.70	
TMC - 5 - 4NTC	5/16	7.93	4/1	9/16	14.3	1.23	31.24	1.52	38.60	
TMC - 6 - 4NTC	3/8	9.52	4/1	5/8	15.9	1.28	32.51	1.57	39.87	
TMC - 6 - 6NTC	3/8	9.52	3/8	11/16	17.5	1.28	32.51	1.57	39.87	
TMC - 6 - 8NTC	3/8	9.52	1/2	7/8	22.2	1.52	38.90	1.82	46.23	
TMC - 6 - 12NTC	3/8	9.52	3/4	1-1/16	27.0	1.59	40.38	1.88	47.75	
TMC - 8 - 8NTC	1/2	12.70	1/2	7/8	22.2	1.53	38.90	1.93	49.02	
TMC - 8 - 12NTC	1/2	12.70	3/4	1-1/16	27.0	1.59	40.38	1.99	50.54	
TMC - 10 - 12NTC	5/8	15.87	3/4	1-1/16	27.0	1.59	40.38	1.99	50.54	
TMC - 12 - 12NTC	3/4	19.05	3/4	1-1/16	27.0	1.59	40.38	1.99	50.54	
TMC - 16 - 16NTC	1	25.40	1	1-3/8	34.9	1.97	50.03	2.45	62.23	

Bored-Through Fittings for Thermocouples, Dip Tubes, and Heat Exchanger Tees

MALE CONNECTOR FOR BONDED WASHER SEAL

TMC-RS

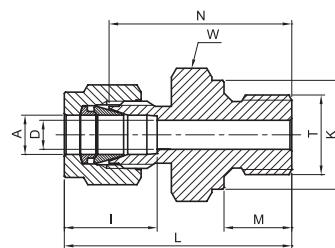
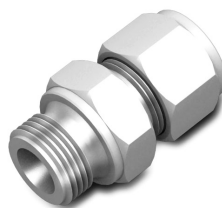

TUBE (METRIC) ISO PARALLEL THREAD									
Part Number	A	T	D	K	W	N	M	L	I
	Tube O.D.	ISO	mm	mm	Hex. flat	mm	mm	mm	mm
	mm	in	mm	mm	mm	mm	mm	mm	mm
TMC - 2M - 2RS	2	G 1/8	1.7	13.8	14	23.4	7.1	30.0	12.9
TMC - 3M - 2RS	3	G 1/8	2.4	13.8	14	23.4	7.1	30.0	12.9
TMC - 3M - 4RS	3	G 1/4	2.4	18.0	19	28.7	11.2	35.3	12.9
TMC - 4M - 2RS	4	G 1/8	2.4	13.8	14	24.1	7.1	30.7	13.7
TMC - 6M - 2RS	6	G 1/8	4.0	13.8	14	24.9	7.1	24.9	15.3
TMC - 6M - 4RS	6	G 1/4	4.8	18.0	19	30.2	11.2	37.6	15.3
TMC - 6M - 6RS	6	G 3/8	4.8	21.8	22	31.5	11.2	38.9	15.3
TMC - 6M - 8RS	6	G 1/2	4.8	26.0	27	37.3	14.2	44.7	15.3
TMC - 8M - 2RS	8	G 1/8	4.0	13.8	15	25.7	7.1	33.2	16.2
TMC - 8M - 4RS	8	G 1/4	6.4	13.8	19	31.0	11.2	38.5	16.2
TMC - 8M - 6RS	8	G 3/8	6.4	21.8	22	32.3	11.2	39.8	16.2
TMC - 8M - 8RS	8	G 1/2	6.4	26.0	27	38.1	14.2	45.6	16.2
TMC - 10M - 4RS	10	G 1/4	5.9	18.0	19	31.8	11.2	39.4	17.2
TMC - 10M - 6RS	10	G 3/8	7.9	21.8	22	33.0	11.2	40.6	17.2
TMC - 10M - 8RS	10	G 1/2	7.9	26.0	27	38.9	14.2	46.5	17.2
TMC - 12M - 4RS	12	G 1/4	5.9	18.0	22	32.5	11.2	42.6	22.8
TMC - 12M - 6RS	12	G 3/8	7.9	21.8	22	33.0	11.2	43.1	22.8
TMC - 12M - 8RS	12	G 1/2	9.5	26.0	27	38.9	14.2	49.0	22.8
TMC - 12M - 12RS	12	G 3/4	9.5	32.0	35	42.7	15.7	52.8	22.8
TMC - 16M - 6RS	16	G 3/8	7.9	21.8	24	33.8	11.2	43.9	24.4
TMC - 16M - 8RS	16	G 1/2	11.9	26.0	27	38.9	14.2	49.0	24.4
TMC - 18M - 8RS	18	G 1/2	11.9	26.0	27	38.9	14.2	49.0	24.4
TMC - 18M - 12RS	18	G 3/4	15.1	32.0	35	42.7	15.7	52.8	24.4
TMC - 20M - 8RS	20	G 1/2	11.9	26.0	30	40.4	14.2	50.5	26.0
TMC - 20M - 12RS	20	G 3/4	15.9	32.0	35	42.7	15.7	52.8	26.0
TMC - 22M - 12RS	22	G 3/4	15.9	32.0	35	42.7	15.7	52.8	26.0
TMC - 22M - 16RS	22	G 1	18.3	39.0	41	45.2	18.3	55.3	26.0
TMC - 25M - 12RS	25	G 3/4	15.9	32.0	35	45.2	15.7	57.5	31.3
TMC - 25M - 16RS	25	G 1	19.8	39	41	47.8	18.3	60.1	31.3
TMC - 28M - 16RS	28	G1	19.8	39	40	49.3	18.3	70.1	36.6
TMC - 28M - 20RS	28	G 1-1/4	21.8	49	50	53.1	19.8	73.9	36.6
TMC - 32M - 20RS	32	G 1-1/4	25.0	49	50	55.9	19.8	78.9	42.0
TMC - 38M - 24RS	38	G 1-1/2	31.8	54.7	55	63.2	22.1	90.8	49.4

Reference Specifications :

- DIN - ISO 228/1
- BS - 2779
- JIS - B0202
- ISO - 228/1-BSP-P

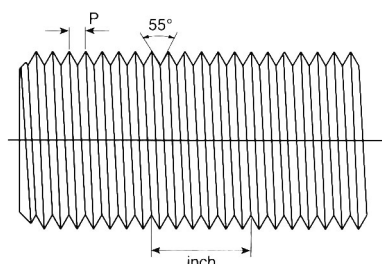

- 55° Thread angle
- Pitch measured in inches
- Root and crest truncation are round
- Diameter measured in inches

For inches, see next page

"D" - Dimension is minimum opening - dimensions are for reference only, and are subject to change without notice.

MALE CONNECTOR FOR BONDED WASHER SEAL

TMC-RS

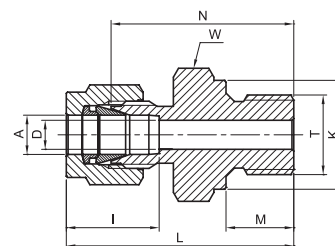

TUBE (INCH) ISO PARALLEL THREAD																	
Part Number	A Tube O.D.		T ISO	D		K		W Hex. flat		N		M		L		I	
	in	mm		in	in	mm	in	mm	in	mm	in	mm	in	mm	in	mm	in
TMC - 2 - 2RS	1/8	3.17	G 1/8	0.09	2.30	0.54	13.8	9/16	14.3	0.92	23.40	0.28	7.10	1.18	30.00	0.50	12.7
TMC - 2 - 4RS	1/8	3.17	G 1/4	0.09	2.30	0.71	18.0	3/4	19.1	1.13	28.70	0.44	11.20	1.39	35.30	0.50	12.7
TMC - 2 - 6RS	1/8	3.17	G 3/8	0.09	2.30	0.86	21.8	7/8	22.2	1.17	29.72	0.44	11.20	1.46	37.00	0.50	12.7
TMC - 2 - 8RS	1/8	3.17	G 1/2	0.09	2.30	1.02	26.0	1-1/16	27.0	1.40	35.70	0.56	14.20	1.69	43.00	0.50	12.7
TMC - 3 - 2RS	3/16	4.76	G 1/8	0.12	3.10	0.54	13.8	9/16	14.3	0.95	24.10	0.28	7.10	1.20	30.70	0.54	13.7
TMC - 4 - 2RS	1/4	6.35	G 1/8	0.16	4.10	0.54	13.8	9/16	14.3	0.98	24.90	0.28	7.10	1.27	32.26	0.60	15.3
TMC - 4 - 4RS	1/4	6.35	G 1/4	0.19	4.80	0.71	18.0	3/4	19.1	1.19	30.20	0.44	11.20	1.48	37.60	0.60	15.3
TMC - 4 - 6RS	1/4	6.35	G 3/8	0.19	4.80	0.86	21.8	7/8	22.2	1.24	31.50	0.44	11.20	1.53	38.86	0.60	15.3
TMC - 4 - 8RS	1/4	6.35	G 1/2	0.19	4.80	1.02	26.0	1-1/16	27.0	1.47	37.30	0.56	14.20	1.76	44.70	0.60	15.3
TMC - 5 - 4RS	5/16	7.93	G 1/4	0.25	6.40	0.71	18.0	3/4	19.1	1.22	31.00	0.44	11.20	1.51	38.36	0.63	16.2
TMC - 5 - 6RS	5/16	7.93	G 3/8	0.25	6.40	0.86	21.8	7/8	22.2	1.27	32.30	0.44	11.20	1.56	39.66	0.63	16.2
TMC - 6 - 4RS	3/8	9.52	G 1/4	0.23	5.80	0.71	18.0	3/4	19.1	1.25	31.75	0.44	11.20	1.54	39.11	0.66	16.9
TMC - 6 - 6RS	3/8	9.52	G 3/8	0.28	7.10	0.86	21.8	7/8	22.2	1.30	33.00	0.44	11.20	1.59	40.40	0.66	16.9
TMC - 6 - 8RS	3/8	9.52	G 1/2	0.28	7.10	1.02	26.0	1-1/16	27.0	1.53	38.86	0.56	14.20	1.82	46.22	0.66	16.9
TMC - 8 - 4RS	1/2	12.70	G 1/4	0.23	5.80	0.71	18.0	1-3/16	20.6	1.28	32.50	0.44	11.20	1.68	42.67	0.90	22.9
TMC - 8 - 6RS	1/2	12.70	G 3/8	0.31	7.90	0.86	21.8	7/8	22.2	1.30	33.00	0.44	11.20	1.70	43.18	0.90	22.9
TMC - 8 - 8RS	1/2	12.70	G 1/2	0.41	10.40	1.02	26.0	1-1/16	27.0	1.47	37.40	0.56	14.20	1.93	49.00	0.90	22.9
TMC - 8 - 12RS	1/2	12.70	G 3/4	0.41	10.40	1.26	32.0	1-5/16	33.3	1.68	42.70	0.62	15.70	2.08	52.86	0.90	22.9
TMC - 10 - 6RS	5/8	15.87	G 3/8	0.31	7.90	0.86	21.8	-	24.0	1.33	33.80	0.44	11.20	1.73	43.96	0.96	24.4
TMC - 10 - 8RS	5/8	15.87	G 1/2	0.47	11.90	1.02	26.0	1-1/16	27.0	1.53	38.90	0.56	14.20	1.93	49.10	0.96	24.4
TMC - 12 - 8RS	3/4	19.05	G 1/2	0.47	11.90	1.02	26.0	1-1/16	27.0	1.53	38.86	0.56	14.20	1.93	49.00	0.96	24.5
TMC - 12 - 12RS	3/4	19.05	G 3/4	0.62	15.80	1.26	32.0	1-5/16	33.3	1.68	42.70	0.62	15.70	2.08	52.83	0.96	24.5
TMC - 16 - 8RS	1	25.40	G 1/2	0.47	11.90	1.02	26.0	1-3/8	34.9	1.72	43.70	0.56	14.20	2.20	55.80	1.23	31.2
TMC - 16 - 12RS	1	25.40	G 3/4	0.62	15.90	1.26	32.0	1-3/8	34.9	1.78	45.20	0.62	15.70	2.65	67.30	1.23	31.2
TMC - 16 - 16RS	1	25.40	G 1	0.78	19.80	1.54	39.0	1-5/8	41.3	1.88	47.80	0.72	18.30	2.36	59.94	1.23	31.2

"D" - Dimension is minimum opening - dimensions are for reference only, and are subject to change without notice.

MALE CONNECTOR FOR METAL GASKET SEAL

TMC-RP

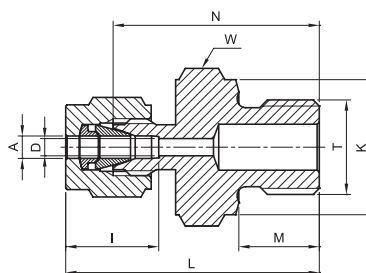

TUBE (METRIC) ISO PARALLEL THREAD									
Part Number	A	T	D	K	W	N	M	L	I
	Tube O.D.	ISO	mm	mm	Hex. flat	mm	mm	mm	mm
	mm	in	mm	mm	mm	mm	mm	mm	mm
TMC - 3M - 2RP	3	G 1/8	2.4	13.8	14	23.4	7.1	30.0	12.9
TMC - 3M - 4RP	3	G 1/4	2.4	18.0	19	28.7	11.2	35.3	12.9
TMC - 4M - 2RP	4	G 1/8	2.4	13.8	14	24.1	7.1	30.7	13.7
TMC - 6M - 2RP	6	G 1/8	4.0	13.8	14	24.9	7.1	32.3	15.3
TMC - 6M - 4RP	6	G 1/4	4.8	18.0	19	30.2	11.2	37.6	15.3
TMC - 6M - 6RP	6	G 3/8	4.8	21.8	22	31.5	11.2	38.9	15.3
TMC - 6M - 8RP	6	G 1/2	4.8	26.0	27	37.3	14.2	44.7	15.3
TMC - 8M - 2RP	8	G 1/8	4.0	13.8	15	25.7	7.1	33.2	16.2
TMC - 8M - 4RP	8	G 1/4	6.4	18.0	19	31.0	11.2	38.5	16.2
TMC - 8M - 6RP	8	G 3/8	6.4	21.8	22	32.3	11.2	39.8	16.2
TMC - 8M - 8RP	8	G 1/2	6.4	26.0	27	38.1	14.2	45.6	16.2
TMC - 10M - 4RP	10	G 1/4	5.9	18.0	19	31.8	11.2	39.4	17.2
TMC - 10M - 6RP	10	G 3/8	7.9	21.8	22	33.0	11.2	40.6	17.2
TMC - 10M - 8RP	10	G 1/2	7.9	26.0	27	38.9	14.2	46.5	19.5
TMC - 12M - 4RP	12	G 1/4	5.9	18.0	22	32.5	11.2	42.6	17.2
TMC - 12M - 6RP	12	G 3/8	7.9	21.8	22	33.0	11.2	43.1	22.8
TMC - 12M - 8RP	12	G 1/2	9.5	26.0	27	38.9	14.2	49.0	22.8
TMC - 12M - 12RP	12	G 3/4	9.5	32.0	35	42.7	15.7	52.8	22.8
TMC - 15M - 8RP	15	G 1/2	11.9	26.0	27	38.9	14.2	49.0	22.8
TMC - 16M - 6RP	16	G 3/8	7.9	21.8	24	33.8	11.2	43.9	22.4
TMC - 16M - 8RP	16	G 1/2	11.9	26.0	27	38.9	14.2	49.0	22.4
TMC - 18M - 8RP	18	G 1/2	11.9	26.0	27	38.9	14.2	49.0	22.4
TMC - 18M - 12RP	18	G 3/4	15.1	32.0	35	42.7	15.7	52.8	22.4
TMC - 20M - 8RP	20	G 1/2	11.9	26.0	30	40.4	14.2	50.5	26.0
TMC - 20M - 12RP	20	G 3/4	15.9	32.0	35	42.7	15.7	52.8	26.0
TMC - 22M - 12RP	22	G 3/4	15.9	32.0	35	42.7	15.7	52.8	26.0
TMC - 22M - 16RP	22	G 1	18.3	39.0	40	45.2	18.3	55.3	26.0
TMC - 25M - 12RP	25	G 3/4	15.9	32.0	35	45.2	15.7	57.5	31.3
TMC - 25M - 16RP	25	G 1	19.8	39	40	47.8	18.3	60.1	31.3
TMC - 28M - 16RP	28	G1	19.8	39.0	40	49.3	18.3	70.1	36.6
TMC - 28M - 20RP	28	G 1-1/4	21.8	49.0	50	53.1	19.8	73.9	36.6
TMC - 32M - 20RP	32	G 1-1/4	25.0	49.0	50	55.9	19.8	78.9	42.0
TMC - 38M - 24RP	38	G 1-1/2	31.8	54.7	55	61.7	20.6	89.3	49.4

Reference Specifications :

- DIN - ISO 2999 • 55° Thread angle
- BS - 21 • Truncation of root and crest are round
- JIS - B0203 • Taper angle 1° 47'

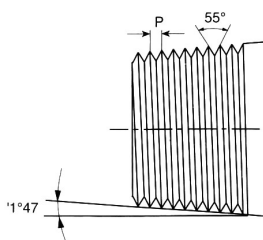

"D" - Dimension is minimum opening - dimensions are for reference only, and are subject to change without notice.

MALE CONNECTOR

TMC-SR

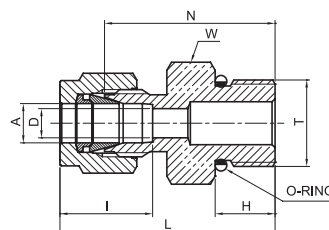

SAE / MS STRAIGHT THREAD BOSS*																
Part Number	A Tube O.D.		T Unif ied Screw	D		W Hex. flat		N		H		L		I		O-ring**
	in	mm		in	mm	in	mm	in	mm	in	mm	in	mm	in	mm	
TMC - 2 - 2SR	1/8	3.17	5/16-24	0.09	2.28	7/16	11.1	0.92	23.37	0.30	7.62	1.18	29.97	0.50	12.7	-902
TMC - 4 - 4SR	1/4	6.35	7/16-20	0.19	4.82	9/16	14.3	1.05	26.67	0.36	9.14	1.34	34.03	0.60	15.3	-904
TMC - 4 - 6SR	1/4	6.35	9/16-18	0.19	4.82	11/16	17.5	1.11	28.19	0.39	9.90	1.40	35.56	0.60	15.3	-906
TMC - 4 - 8SR	1/4	6.35	3/4-16	0.19	4.82	7/8	22.2	1.19	30.20	0.44	11.17	1.48	37.59	0.60	15.3	-908
TMC - 4 - 10SR	1/4	6.35	7/8-14	0.19	4.82	1	25.4	1.31	33.27	0.50	12.70	1.60	40.64	0.60	15.3	-910
TMC - 5 - 5SR	5/16	7.93	1/2-20	0.25	6.40	5/8	15.9	1.08	27.43	0.36	9.14	1.37	34.80	0.64	16.2	-905
TMC - 6 - 4SR	3/8	9.52	7/16-20	0.20	5.10	5/8	15.9	1.11	28.19	0.36	9.14	1.40	35.56	0.66	16.9	-904
TMC - 6 - 6SR	3/8	9.52	9/16-18	0.28	7.11	11/16	17.5	1.17	29.71	0.39	9.90	1.46	37.08	0.66	16.9	-906
TMC - 6 - 8SR	3/8	9.52	3/4-16	0.28	7.11	7/8	22.2	1.25	31.75	0.44	11.17	1.54	39.11	0.66	16.9	-908
TMC - 6 - 10SR	3/8	9.52	7/8-14	0.28	7.11	1	25.4	1.37	34.80	0.50	12.70	1.66	42.16	0.66	16.9	-910
TMC - 8 - 6SR	1/2	12.70	9/16-18	0.28	7.11	13/16	20.6	1.14	28.95	0.39	9.90	1.54	39.11	0.90	22.9	-906
TMC - 8 - 8SR	1/2	12.70	3/4-16	0.41	10.41	7/8	22.2	1.25	31.75	0.44	11.17	1.65	41.91	0.90	22.9	-908
TMC - 8 - 10SR	1/2	12.70	7/8-14	0.41	10.41	1	25.4	1.37	34.80	0.50	12.70	1.77	44.96	0.90	22.9	-910
TMC - 8 - 12SR	1/2	12.70	1-1/16-12	0.41	10.41	1-1/4	31.8	1.53	38.86	0.59	14.98	1.93	49.02	0.90	22.9	-912
TMC - 10 - 8SR	5/8	15.87	3/4-16	0.42	10.66	15/16	23.8	1.25	31.75	0.44	11.17	1.65	41.91	0.96	24.4	-908
TMC - 10 - 10SR	5/8	15.87	7/8-14	0.50	12.70	1	25.4	1.38	35.05	0.50	12.70	1.78	45.21	0.96	24.4	-910
TMC - 12 - 8SR	3/4	19.05	3/4-16	0.42	10.66	1-1/16	27.0	1.41	35.81	0.44	11.17	1.81	46.00	0.96	24.5	-908
TMC - 12 - 12SR	3/4	19.05	1-1/16-12	0.62	15.74	1-1/4	31.8	1.53	38.86	0.59	14.98	1.93	49.02	0.96	24.5	-912
TMC - 14 - 14SR	7/8	22.22	1-3/16-12	0.72	18.29	1-3/8	34.9	1.53	38.86	0.59	14.98	1.93	49.02	1.02	25.9	-914
TMC - 16 - 12SR	1	25.40	1-1/16-12	0.66	16.76	1-3/8	34.9	1.62	41.20	0.59	14.98	2.10	53.34	1.23	31.2	-912
TMC - 16 - 16SR	1	25.40	1-5/16-12	0.88	22.35	1-1/2	38.1	1.66	42.16	0.59	14.98	2.14	54.35	1.23	31.2	-916
TMC - 20 - 20SR	1-1/4	31.75	1-5/8-12	1.09	27.70	1-7/8	47.6	1.82	46.23	0.59	15.10	2.69	68.33	1.62	41.2	-920
TMC - 24 - 24SR	1-1/2	38.10	1-7/8-12	1.34	34.00	2-1/8	54.0	1.99	50.55	0.59	15.10	3.06	77.72	1.97	50.0	-924
TMC - 32 - 32SR	2	50.80	2-1/2-12	1.81	45.97	2-3/4	69.9	2.53	64.26	0.59	15.10	4.00	101.60	2.66	67.6	-932

"D" - Dimension is minimum opening - dimensions are for reference only, and are subject to change without notice.

* SAE J 1926 and MS 16142. See page 61 for mounting dimensions.

** O-Rings used are KFM (Viton®) 90 Durometer. Other O-Ring material are available on request.

MALE CONNECTOR

TMC-NOR

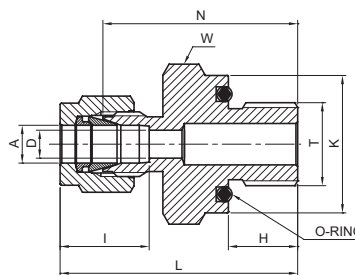

O-SEAL NPT TAPERED THREAD																		
Part Number	A Tube O.D.		T NPT Short	D		K		W Hex. flat		N		H		L		I		O-ring*
	in	mm	in	in	mm	in	mm	in	mm	in	mm	in	mm	in	mm	in	mm	
TMC - 2 - 2NOR	1/8	3.17	1/8	0.09	2.28	0.74	18.79	3/4	19.1	1.03	26.16	0.28	7.11	1.29	32.76	0.50	12.7	-111
TMC - 4 - 2NOR	1/4	6.35	1/8	0.19	4.82	0.74	18.79	3/4	19.1	1.09	27.70	0.28	7.11	1.38	35.05	0.60	15.3	-111
TMC - 4 - 4NOR	1/4	6.35	1/4	0.19	4.82	0.93	23.62	15/16	23.8	1.22	31.00	0.38	9.65	1.51	38.40	0.60	15.3	-113
TMC - 6 - 4NOR	3/8	9.52	1/4	0.28	7.11	0.93	23.62	15/16	23.8	1.28	32.51	0.38	9.65	1.57	39.88	0.66	16.9	-113
TMC - 6 - 6NOR	3/8	9.52	3/8	0.28	7.11	1.12	28.45	1-1/8	28.6	1.34	34.04	0.41	10.41	1.63	41.40	0.66	16.9	-116
TMC - 6 - 8NOR	3/8	9.52	1/2	0.28	7.11	1.30	33.02	1-5/16	33.3	1.56	39.62	0.53	13.46	1.85	46.99	0.66	16.9	-212
TMC - 8 - 8NOR	1/2	12.70	1/2	0.41	10.41	1.30	33.02	1-5/16	33.3	1.56	39.62	0.53	13.46	1.96	49.78	0.90	22.9	-212

MALE CONNECTOR

TMC-OR

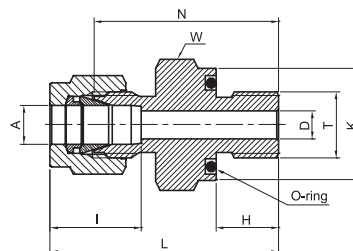

O-SEAL MALE UNF THREAD																		
Part Number	A Tube O.D.		T Unif ied Screw	D		K		W Hex. flat		N		H		L		I		O-ring*
	in	mm	in	in	mm	in	mm	in	mm	in	mm	in	mm	in	mm	in	mm	
TMC - 1 - 2OR	1/16	1.58	5/16-24	0.05	1.27	0.55	14.0	9/16	14.3	0.90	22.86	0.34	8.63	1.05	26.67	0.34	8.6	-011
TMC - 2 - 2OR	1/8	3.17	5/16-24	0.09	2.28	0.55	14.0	9/16	14.3	1.03	26.20	0.34	8.63	1.29	32.77	0.50	12.7	-011
TMC - 3 - 3OR	3/16	4.76	3/8-24	0.12	3.04	0.62	15.75	5/8	15.9	1.09	27.70	0.38	9.65	1.35	34.29	0.54	13.7	-012
TMC - 4 - 4OR	1/4	6.35	7/16-20	0.19	4.22	0.74	18.80	3/4	19.1	1.22	31.00	0.41	10.41	1.51	38.35	0.60	15.3	-111
TMC - 5 - 5OR	5/16	7.93	1/2-20	0.25	6.35	0.86	21.84	7/8	22.2	1.31	33.30	0.44	11.17	1.60	40.64	0.64	16.2	-112
TMC - 6 - 6OR	3/8	9.52	9/16-18	0.28	7.11	0.93	23.62	15/16	23.8	1.38	35.05	0.47	11.93	1.67	40.89	0.66	16.9	-113
TMC - 8 - 8OR	1/2	12.70	3/4-16	0.41	10.41	1.12	28.45	1-1/8	28.6	1.41	35.81	0.47	11.93	1.81	45.77	0.90	22.9	-116
TMC - 12 - 12OR	3/4	19.05	1-1/16-12	0.62	15.74	1.49	37.85	1-1/2	38.1	1.66	42.20	0.56	14.22	2.06	52.32	0.96	24.5	121
TMC - 16 - 16OR	1	25.40	1-5/16-12	0.88	22.35	1.74	44.20	1-3/4	44.5	1.81	45.97	0.56	14.22	2.29	58.17	1.23	31.2	125

"D" - Dimension is minimum opening - dimensions are for reference only, and are subject to change without notice.

* O-Rings used are NBR (Perbunan®) 70 Durometer.

MALE PIPE WELD CONNECTOR

TMPWC

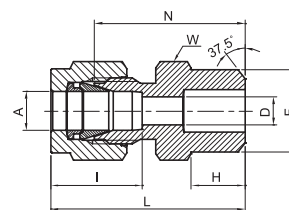

TUBE (METRIC) TO PIPE (INCH)												
Part Number	A Tube O.D.		F Pipe size		D		W Hex. flat		N	H	L	I
	mm	in	mm	in	mm	in	mm	in	mm	mm	mm	mm
TMPWC - 3M - 2TW	3	1/8	10.30		2.4		12		23.1	9.7	30.5	12.9
TMPWC - 4M - 2TW	4	1/8	10.30		2.4		12		24.1	9.7	31.2	13.7
TMPWC - 6M - 2TW	6	1/8	10.30		4.8		14		25.4	9.7	32.8	15.3
TMPWC - 6M - 4TW	6	1/4	13.70		4.8		14		30.2	14.2	37.9	15.3
TMPWC - 8M - 2TW	8	1/8	10.30		5.1		15		26.7	9.7	34.2	16.2
TMPWC - 8M - 4TW	8	1/4	13.70		6.4		15		31.2	14.2	38.7	16.2
TMPWC - 8M - 8TW	8	1/2	21.34		6.4		22		37.3	19.0	44.8	16.2
TMPWC - 10M - 4TW	10	1/4	13.70		7.1		18		33.3	14.2	40.9	17.2
TMPWC - 10M - 6TW	10	3/8	17.10		7.9		18		32.5	14.2	40.9	17.2
TMPWC - 10M - 8TW	10	1/2	21.34		7.9		22		38.1	19.0	45.8	17.2
TMPWC - 12M - 4TW	12	1/4	13.70		7.1		22		33.3	14.2	43.4	22.8
TMPWC - 12M - 6TW	12	3/8	17.10		9.5		22		33.3	14.2	43.4	22.8
TMPWC - 12M - 8TW	12	1/2	21.34		9.5		22		38.1	19.0	49.0	22.8
TMPWC - 15M - 8TW	15	1/2	21.34		11.9		24		38.9	19.0	49.0	24.4
TMPWC - 16M - 8TW	16	1/2	21.34		12.7		24		38.9	19.0	49.0	24.4
TMPWC - 18M - 8TW	18	1/2	21.34		13.5		27		40.4	19.0	50.5	24.4

TUBE (INCH) TO PIPE (INCH)																
Part Number	A Tube O.D.		F Pipe size		D		W Hex. flat		N		H		L		I	
	in	mm	in	mm	in	mm	in	mm	in	mm	in	mm	in	mm	in	mm
TMPWC - 2 - 2TW	1/8	3.17	1/8	10.30	0.09	2.28	7/16	11.1	0.94	23.88	0.38	9.65	1.20	30.48	0.50	12.7
TMPWC - 3 - 2TW	3/16	4.76	1/8	10.30	0.12	3.04	7/16	11.1	0.97	24.60	0.38	9.65	1.23	31.25	0.54	13.7
TMPWC - 4 - 2TW	1/4	6.35	1/8	10.30	0.19	4.82	1/2	12.7	1.00	25.40	0.38	9.65	1.29	32.77	0.60	15.3
TMPWC - 4 - 4TW	1/4	6.35	1/4	13.70	0.19	4.82	9/16	14.3	1.19	30.22	0.56	14.22	1.48	37.59	0.60	15.3
TMPWC - 5 - 2TW	5/16	7.93	1/8	10.30	0.20	5.08	9/16	14.3	1.05	26.67	0.38	9.65	1.34	34.04	0.64	16.2
TMPWC - 5 - 4TW	5/16	7.93	1/4	13.70	0.25	6.35	9/16	14.3	1.23	31.24	0.56	14.22	1.52	38.61	0.64	16.2
TMPWC - 6 - 4TW	3/8	9.52	1/4	13.70	0.28	7.11	5/8	15.9	1.28	32.51	0.56	14.22	1.57	39.87	0.66	16.9
TMPWC - 6 - 6TW	3/8	9.52	3/8	17.10	0.28	7.11	11/16	17.5	1.28	32.51	0.56	14.22	1.57	39.87	0.66	16.9
TMPWC - 6 - 8TW	3/8	9.52	1/2	21.34	0.28	7.11	7/8	22.2	1.53	38.86	0.75	19.05	1.82	46.22	0.66	16.9
TMPWC - 8 - 6TW	1/2	12.70	3/8	17.10	0.41	10.41	13/16	20.6	1.31	33.27	0.56	14.22	1.71	44.43	0.90	22.9
TMPWC - 8 - 8TW	1/2	12.70	1/2	21.34	0.41	10.41	7/8	22.2	1.53	38.86	0.75	19.05	1.93	49.00	0.90	22.9
TMPWC - 8 - 12TW	1/2	12.70	3/4	26.67	0.41	10.41	1-1/16	27.0	1.59	40.40	0.75	19.05	1.99	50.55	0.90	22.9
TMPWC - 10 - 8TW	5/8	15.87	1/2	21.34	0.50	12.70	15/16	23.8	1.53	38.86	0.75	19.05	1.93	49.02	0.96	24.4
TMPWC - 12 - 12TW	3/4	19.05	3/4	26.67	0.62	15.74	1-1/16	27.0	1.59	40.40	0.75	19.05	1.99	50.55	0.96	24.5
TMPWC - 16 - 16TW	1	25.4	1	33.4	0.88	22.35	1-3/8	34.9	1.97	50.03	0.94	23.87	2.45	62.23	1.23	31.2
TMPWC - 20 - 20TW	1-1/2	31.75	1-1/4	42.16	1.09	27.7	1-3/4	44.5	2.17	55.12	0.94	23.88	3.04	77.22	1.62	41.2
TMPWC - 24 - 24TW	1-1	38.1	1-1/2	48.26	1.34	34	2-1/8	54.0	2.43	61.72	1.03	26.16	3.5	88.9	1.97	50.0
TMPWC - 32 - 32TW	2	50.8	2	60.33	1.81	45.97	2-3/4	69.9	3.0	76.2	1.06	26.92	4.47	113.34	2.66	67.6

“D” - Dimension is the minimum opening. These fittings may have a larger opening at the weld end. The wall thickness of welding edge is based on SCH 80.

TUBE SOCKET WELD CONNECTOR

TTSWC

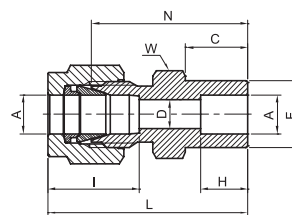

TUBE (INCH) TO TUBE (INCH)

Part Number	A Tube O.D.		C		D		W Hex. flat		F		H		L		I		N	
	in	mm	in	mm	in	mm	in	mm	in	mm	in	mm	in	mm	in	mm	in	mm
TTSWC - 2 - 2SW	1/8	3.17	0.34	8.64	0.09	2.28	7/16	11.1	0.31	7.87	0.25	6.35	0.50	28.96	1.14	12.7	0.88	22.35
TTSWC - 4 - 4SW	1/4	6.35	0.41	10.41	0.19	4.80	1/2	12.7	0.44	11.18	0.31	7.90	0.60	33.53	1.32	15.3	1.03	26.16
TTSWC - 6 - 6SW	3/8	9.52	0.47	11.94	0.28	7.10	5/8	15.9	0.62	15.75	0.38	9.65	0.66	37.60	1.48	16.9	1.19	30.23
TTSWC - 8 - 8SW	1/2	12.70	0.47	11.94	0.41	10.40	13/16	20.6	0.75	19.05	0.50	12.70	0.90	41.15	1.62	22.9	1.22	31.00
TTSWC - 12 - 12SW	3/4	19.05	0.47	11.94	0.62	15.80	1-1/16	27.0	1.05	26.67	0.56	14.20	0.96	43.43	1.71	24.5	1.31	33.28
TTSWC - 16 - 16SW	1	25.40	0.56	14.22	0.88	22.35	1-3/8	34.9	1.31	33.27	0.75	19.05	1.23	52.58	2.07	31.2	1.59	40.40

"D" - Dimension is minimum opening - dimensions are for reference only, and are subject to change without notice.

WELD BULKHEAD UNION

TWBU

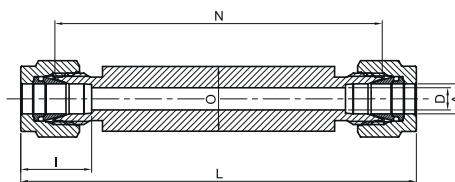
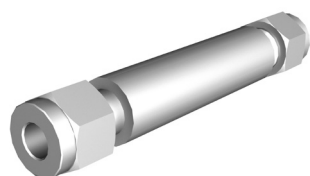

TUBE (METRIC) TO MALE NPT THREAD						
Part Number	A Tube O.D.	D	N	L	I	O
	mm	mm	mm	mm	mm	mm
TWBU - 2M	2	1.7	67.3	80.5	12.9	12.0
TWBU - 3M	3	2.4	67.3	80.5	12.9	12.0
TWBU - 4M	4	2.4	69.0	82.2	13.7	12.0
TWBU - 6M	6	4.8	70.5	85.3	15.3	12.0
TWBU - 8M	8	6.3	72.1	87.1	16.2	16.0
TWBU - 10M	10	7.9	73.7	88.9	17.2	19.0
TWBU - 12M	12	9.5	73.6	93.8	22.8	23.0
TWBU - 15M	15	11.9	73.7	93.9	22.8	25.0
TWBU - 16M	16	12.7	73.7	93.9	24.4	28.0
TWBU - 18M	18	15.1	73.7	93.9	24.4	28.0
TWBU - 20M	20	15.9	73.7	93.9	24.4	32.0
TWBU - 22M	22	18.3	73.7	93.9	26.0	32.0
TWBU - 25M	25	21.8	78.6	103.2	31.3	38.0
TWBU - 28M	28	21.8	81.7	123.3	36.6	45.0
TWBU - 32M	32	28.6	87.1	132.8	42.0	50.0
TWBU - 38M	38	33.7	90.9	146.1	49.4	60.0

TUBE (METRIC) TO MALE NPT THREAD								
Part Number	A Tube O.D.		D		N	L	I	O
	mm		mm		mm	mm	mm	mm
TWBU - 1	1/16	1.58	0.05	1.27	64.2	71.82	8.6	10.00
TWBU - 2	1/8	3.17	0.09	2.28	67.2	80.41	12.7	12.00
TWBU - 3	3/16	4.76	0.12	3.04	69.0	82.2	13.7	12.00
TWBU - 4	1/4	6.35	0.19	4.82	70.8	85.53	15.3	14.00
TWBU - 5	5/16	7.93	0.25	6.35	73.7	88.4	16.3	16.00
TWBU - 6	3/8	9.52	0.28	7.11	73.7	88.43	16.9	19.00
TWBU - 8	1/2	12.70	0.41	10.41	73.7	94.02	22.9	23.00
TWBU - 10	5/8	15.87	0.50	12.7	73.7	94.02	24.4	25.00
TWBU - 12	3/4	19.05	0.62	15.74	73.7	94.02	24.5	28.00
TWBU - 14	7/8	22.22	0.72	18.28	73.7	93.76	25.9	32.00
TWBU - 16	1	25.40	0.88	22.35	78.5	102.89	31.2	35.00
TWBU - 20	1-1/4	31.75	1.09	27.70	83.9	128.1	41.2	50.00
TWBU - 24	1-1/2	38.10	1.34	34.00	86.1	140.45	50.0	55.00
TWBU - 32	2	50.80	1.81	45.97	100.9	175.58	67.6	80.00

"D" - Dimension is minimum opening - dimensions are for reference only, and are subject to change without notice.

MALE 90° ELBOW

TME

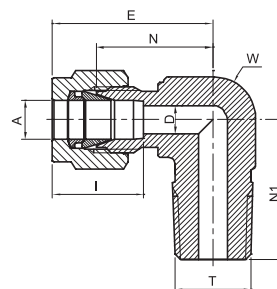

TUBE (METRIC) MALE NPT THREAD

Part Number	A	T	D	W		N	E	N1	I
	Tube O.D.	NPT		Wrench flat					
	mm	in	mm	in	mm	mm	mm	mm	mm
TME - 3M - 2N	3	1/8	2.4	7/16	11.1	17.0	23.6	17.8	12.9
TME - 3M - 4N	3	1/4	2.4	1/2	12.7	18.0	24.6	23.4	12.9
TME - 4M - 2N	4	1/8	2.4	1/2	12.7	18.8	25.4	18.8	13.7
TME - 4M - 4N	4	1/4	2.4	1/2	12.7	18.8	25.4	23.4	13.7
TME - 6M - 2N	6	1/8	4.8	1/2	12.7	19.6	27.0	18.8	15.3
TME - 6M - 4N	6	1/4	4.8	1/2	12.7	19.6	27.0	23.4	15.3
TME - 6M - 6N	6	3/8	4.8	11/16	17.5	22.4	29.8	26.2	15.3
TME - 6M - 8N	6	1/2	4.8	13/16	20.6	24.4	31.8	33.0	15.3
TME - 8M - 2N	8	1/8	4.8	9/16	14.3	21.3	28.8	19.8	16.2
TME - 8M - 4N	8	1/4	6.4	9/16	14.3	21.3	28.8	24.4	16.2
TME - 8M - 6N	8	3/8	6.4	11/16	17.5	23.1	30.6	26.2	16.2
TME - 8M - 8N	8	1/2	6.4	13/16	20.6	25.1	32.6	33.0	16.2
TME - 10M - 2N	10	1/8	4.8	11/16	17.5	23.9	31.5	21.6	17.2
TME - 10M - 4N	10	1/4	7.1	11/16	17.5	23.9	31.5	26.2	17.2
TME - 10M - 6N	10	3/8	7.9	11/16	17.5	23.9	31.5	26.2	17.2
TME - 10M - 8N	10	1/2	7.9	13/16	20.6	25.9	33.5	33.0	17.2
TME - 12M - 2N	12	1/8	4.8	13/16	20.6	25.9	36.0	23.6	22.8
TME - 12M - 4N	12	1/4	7.1	13/16	20.6	25.9	36.0	28.2	22.8
TME - 12M - 6N	12	3/8	9.5	13/16	20.6	25.9	36.0	28.2	22.8
TME - 12M - 8N	12	1/2	9.5	13/16	20.6	25.9	36.0	33.0	22.8
TME - 12M - 12N	12	3/4	9.5	1-1/16	27.0	29.7	39.8	36.8	22.8
TME - 15M - 8N	15	1/2	11.9	15/16	23.8	27.9	38.0	35.1	24.4
TME - 16M - 6N	16	3/8	9.5	15/16	23.8	27.9	38.0	30.2	24.4
TME - 16M - 8N	16	1/2	11.9	15/16	23.8	27.9	38.0	35.1	24.4
TME - 16M - 12N	16	3/4	12.7	1-1/16	27.0	29.7	39.8	36.8	24.4
TME - 18M - 8N	18	1/2	11.9	1-1/16	27.0	29.7	39.8	36.8	24.4
TME - 18M - 12N	18	3/4	15.1	1-1/16	27.0	29.7	39.8	36.8	24.4
TME - 20M - 8N	20	1/2	11.9	1-3/8	34.9	34.5	44.6	41.7	26.0
TME - 20M - 12N	20	3/4	15.9	1-3/8	34.9	34.5	44.6	41.7	26.0
TME - 22M - 12N	22	3/4	15.9	1-3/8	34.9	34.5	44.6	41.7	26.0
TME - 22M - 16N	22	1	18.3	1-3/8	34.9	34.5	44.6	46.5	26.0
TME - 25M - 12N	25	3/4	15.9	1-3/8	34.9	36.8	49.1	41.7	31.3
TME - 25M - 16N	25	1	21.8	1-3/8	34.9	36.8	49.1	46.5	31.3

For inches, see next page

"D" - Dimension is minimum opening - dimensions are for reference only, and are subject to change without notice.

MALE 90° ELBOW

TME

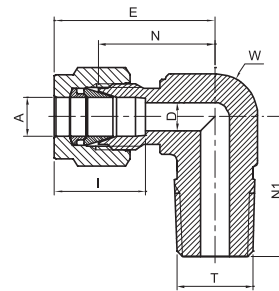
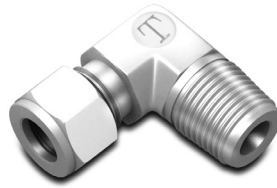

TUBE (INCH) MALE NPT THREAD															
Part Number	A Tube O.D.		T NPT	D		W Wrench flat		N		E		N1		I	
	in	mm		in	mm	in	mm	in	mm	in	mm	in	mm	in	mm
TME - 1 - 1N	1/16	1.58	1/16	0.05	1.27	7/16	11.1	0.60	15.24	0.75	19.05	0.70	17.78	0.34	8.6
TME - 1 - 2N	1/16	1.58	1/8	0.05	1.27	7/16	11.1	0.60	15.24	0.75	19.05	0.70	17.78	0.34	8.6
TME - 2 - 2N	1/8	3.17	1/8	0.09	2.28	7/16	11.1	0.67	17.02	0.93	23.62	0.70	17.78	0.50	12.7
TME - 2 - 4N	1/8	3.17	1/4	0.09	2.28	1/2	12.7	0.71	18.03	0.97	24.64	0.92	23.37	0.50	12.7
TME - 3 - 2N	3/16	4.76	1/8	0.12	3.04	1/2	12.7	0.74	18.80	1.00	25.40	0.74	18.80	0.54	13.7
TME - 3 - 4N	3/16	4.76	1/4	0.12	3.04	1/2	12.7	0.74	18.80	1.00	25.40	0.92	23.37	0.54	13.7
TME - 4 - 1N	1/4	6.35	1/16	0.12	3.04	1/2	12.7	0.77	19.55	1.06	26.9	0.74	18.79	0.60	15.3
TME - 4 - 2N	1/4	6.35	1/8	0.19	4.82	1/2	12.7	0.77	19.56	1.06	26.92	0.74	18.80	0.60	15.3
TME - 4 - 4N	1/4	6.35	1/4	0.19	4.82	1/2	12.7	0.77	19.56	1.06	26.92	0.92	23.37	0.60	15.3
TME - 4 - 6N	1/4	6.35	3/8	0.19	4.82	11/16	17.5	0.88	22.35	1.17	29.71	1.03	26.16	0.60	15.3
TME - 4 - 8N	1/4	6.35	1/2	0.19	4.82	13/16	20.6	0.96	24.38	1.25	31.75	1.30	33.02	0.60	15.3
TME - 5 - 2N	5/16	7.93	1/8	0.19	4.82	9/16	14.3	0.84	21.34	1.13	28.70	0.78	19.81	0.64	16.2
TME - 5 - 4N	5/16	7.93	1/4	0.25	6.35	9/16	14.3	0.84	21.34	1.13	28.70	0.96	24.38	0.64	16.2
TME - 5 - 6N	5/16	7.93	3/8	0.25	6.35	11/16	17.5	0.91	23.11	1.20	30.48	1.03	26.16	0.64	16.2
TME - 6 - 2N	3/8	9.52	1/8	0.19	4.82	5/8	15.9	0.91	23.11	1.20	30.48	0.82	20.83	0.66	16.9
TME - 6 - 4N	3/8	9.52	1/4	0.28	7.11	5/8	15.9	0.91	23.11	1.20	30.48	1.00	25.40	0.66	16.9
TME - 6 - 6N	3/8	9.52	3/8	0.28	7.11	11/16	17.5	0.94	23.87	1.23	31.24	1.03	26.16	0.66	16.9
TME - 6 - 8N	3/8	9.52	1/2	0.28	7.11	13/16	20.6	1.02	25.90	1.31	33.28	1.30	33.02	0.66	16.9
TME - 6 - 12N	3/8	9.52	3/4	0.28	7.11	1-1/16	27.0	1.17	29.71	1.46	37.08	1.45	36.83	0.66	16.9
TME - 8 - 4N	1/2	12.70	1/4	0.28	7.11	13/16	20.6	1.02	25.90	1.42	36.07	1.11	28.19	0.90	22.9
TME - 8 - 6N	1/2	12.70	3/8	0.38	9.65	13/16	20.6	1.02	25.90	1.42	36.07	1.11	28.19	0.90	22.9
TME - 8 - 8N	1/2	12.70	1/2	0.41	10.41	13/16	20.6	1.02	25.90	1.42	36.07	1.30	33.02	0.90	22.9
TME - 8 - 12N	1/2	12.70	3/4	0.41	10.41	1-11/16	27.0	1.17	29.71	1.57	39.88	1.45	36.83	0.90	22.9
TME - 10 - 6N	5/8	15.87	3/8	0.38	9.61	15/16	23.8	1.10	27.94	1.50	38.10	1.19	30.23	0.96	24.4
TME - 10 - 8N	5/8	15.87	1/2	0.47	11.94	15/16	23.8	1.10	27.94	1.50	38.10	1.38	35.05	0.96	24.4
TME - 10 - 12N	5/8	15.87	3/4	0.50	12.70	1-1/16	27.0	1.17	29.71	1.57	39.88	1.45	36.83	0.96	24.4
TME - 12 - 8N	3/4	19.05	1/2	0.47	15.74	1-1/16	27.0	1.17	29.71	1.57	39.88	1.45	36.83	0.96	24.5
TME - 12 - 12N	3/4	19.05	3/4	0.62	15.74	1-1/16	27.0	1.17	29.71	1.57	39.88	1.45	36.83	0.96	24.5
TME - 14 - 12N	7/8	22.22	3/4	0.62	15.74	1-3/16	34.9	1.36	34.54	1.76	44.70	1.64	41.66	1.02	25.9
TME - 16 - 12N	1	25.40	3/4	0.62	15.74	1-3/8	34.9	1.45	36.83	1.93	49.02	1.64	41.66	1.23	31.2
TME - 16 - 16N	1	25.4	1	0.88	22.35	1-3/8	34.9	1.45	36.83	1.93	49.02	1.83	46.48	1.23	31.2
TME - 20 - 20N	1-1/4	31.75	1-1/4	1.09	27.7	1-11/16	42.9	1.75	44.45	2.62	66.5	1.88	47.75	1.62	41.2
TME - 24 - 24N	1-1/2	38.1	1-1/2	1.34	34	2	50.8	2.0	50.8	3.07	78.0	2.38	60.45	1.97	50.0
TME - 32 - 32N	2	50.8	2	1.81	45.97	2-3/4	69.9	2.75	69.85	4.22	107.19	2.78	70.61	2.66	67.6

"D" - Dimension is minimum opening - dimensions are for reference only, and are subject to change without notice.

MALE 90° ELBOW

TME

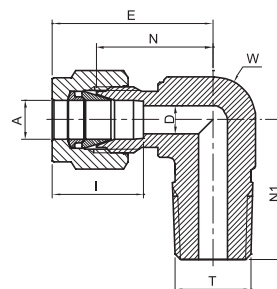

TUBE (METRIC) ISO TAPERED THREAD									
Part Number	A	T	D	W		N	E	N1	I
	Tube O.D.	ISO	mm	in	mm	mm	mm	mm	mm
TME - 3M - 2P	3	R 1/8	2.4	7/16	11.1	17.0	23.6	17.8	12.9
TME - 3M - 4P	3	R 1/4	2.4	1/2	12.7	18.0	24.6	23.4	12.9
TME - 4M - 2P	4	R 1/8	2.4	1/2	12.7	18.8	25.4	18.8	13.7
TME - 4M - 4P	4	R 1/4	2.4	1/2	12.7	18.8	25.4	23.4	13.7
TME - 6M - 2P	6	R 1/8	4.8	1/2	12.7	19.6	27.0	18.8	15.3
TME - 6M - 4P	6	R 1/4	4.8	1/2	12.7	19.6	27.0	23.4	15.3
TME - 6M - 6P	6	R 3/8	4.8	11/16	17.5	22.4	29.8	26.2	15.3
TME - 6M - 8P	6	R 1/2	4.8	13/16	20.6	24.4	31.8	33.0	15.3
TME - 8M - 2P	8	R 1/8	4.8	9/16	14.3	21.3	28.8	19.8	16.2
TME - 8M - 4P	8	R 1/4	6.4	9/16	14.3	21.3	28.8	24.4	16.2
TME - 8M - 6P	8	R 3/8	6.4	11/16	17.5	23.1	30.6	26.2	16.2
TME - 8M - 8P	8	R 1/2	6.4	13/16	20.6	25.1	32.6	33.0	16.2
TME - 10M - 2P	10	R 1/8	4.8	11/16	17.5	23.9	31.5	21.6	17.2
TME - 10M - 4P	10	R 1/4	7.1	11/16	17.5	23.9	31.5	26.2	17.2
TME - 10M - 6P	10	R 3/8	7.9	11/16	17.5	23.9	31.5	26.2	17.2
TME - 10M - 8P	10	R 1/2	7.9	13/16	20.6	25.9	33.5	33.0	17.2
TME - 12M - 2P	12	R 1/8	4.8	13/16	20.6	25.9	36.0	23.6	22.8
TME - 12M - 4P	12	R 1/4	7.1	13/16	20.6	25.9	36.0	28.2	22.8
TME - 12M - 6P	12	R 3/8	9.5	13/16	20.6	25.9	36.0	28.2	22.8
TME - 12M - 8P	12	R 1/2	9.5	13/16	20.6	25.9	36.0	33.0	22.8
TME - 12M - 12P	12	R 3/4	9.5	1-1/16	27.0	29.7	39.8	36.8	22.8
TME - 16M - 6P	16	R 3/8	9.5	15/16	23.8	27.9	38.0	30.2	24.4
TME - 16M - 8P	16	R 1/2	11.9	15/16	23.8	27.9	38.0	35.1	24.4
TME - 18M - 8P	18	R 1/2	11.9	1-1/16	27.0	29.7	39.8	36.8	24.4
TME - 18M - 12P	18	R 3/4	15.1	1-1/16	27.0	29.7	39.8	36.8	24.4
TME - 20M - 8P	20	R 1/2	11.9	1-3/8	34.9	34.5	44.6	41.7	26.0
TME - 20M - 12P	20	R 3/4	15.9	1-3/8	34.9	34.5	44.6	41.7	26.0
TME - 22M - 12P	22	R 3/4	15.9	1-3/8	34.9	34.5	44.6	41.7	26.0
TME - 22M - 16P	22	R 1	18.3	1-3/8	34.9	34.5	44.6	46.5	26.0
TME - 25M - 12P	25	R 3/4	15.9	1-3/8	34.9	36.8	49.1	41.7	31.3
TME - 25M - 16P	25	R 1	21.8	1-3/8	34.9	36.8	49.1	46.5	31.3

Reference Specifications :

- DIN - ISO 2999 • 55° Thread angle
- BS - 21 • Truncation of root and crest are round
- JIS - B0203 • Taper angle 1° 47'

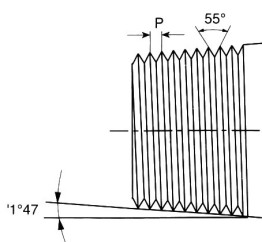

"D" - Dimension is minimum opening - dimensions are for reference only, and are subject to change without notice.

MALE 90° ELBOW

TME

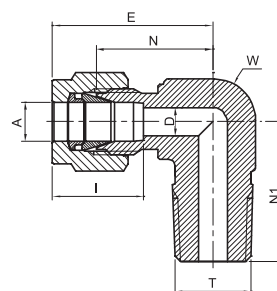

TUBE (INCH) ISO TAPERED THREAD															
Part Number	A Tube O.D.		T ISO	D		W Wrench flat		N		E		N1		I	
	in	mm	in	in	mm	in	mm	in	mm	in	mm	in	mm	in	mm
TME - 1 - 1P	1/16	1.58	R 1/16	0.05	1.27	7/16	11.1	0.60	15.24	0.75	19.05	0.70	17.78	0.34	8.6
TME - 1 - 2P	1/16	1.58	R 1/8	0.05	1.27	7/16	11.1	0.60	15.24	0.75	19.05	0.70	17.78	0.34	8.6
TME - 2 - 2P	1/8	3.17	R 1/8	0.09	2.28	7/16	11.1	0.67	17.02	0.93	23.62	0.70	17.78	0.50	12.7
TME - 2 - 4P	1/8	3.17	R 1/4	0.09	2.28	1/2	12.7	0.71	18.03	0.97	24.64	0.92	23.37	0.50	12.7
TME - 3 - 2P	3/16	4.76	R 1/8	0.12	3.04	1/2	12.7	0.74	18.80	1.00	25.40	0.74	18.80	0.54	13.7
TME - 3 - 4P	3/16	4.76	R 1/4	0.12	3.04	1/2	12.7	0.74	18.80	1.00	25.40	0.92	23.37	0.54	13.7
TME - 4 - 1P	1/4	6.35	R 1/16	0.12	3.04	1/2	12.7	0.77	19.55	1.06	26.9	0.74	18.79	0.60	15.3
TME - 4 - 2P	1/4	6.35	R 1/8	0.19	4.82	1/2	12.7	0.77	19.56	1.06	26.92	0.74	18.80	0.60	15.3
TME - 4 - 4P	1/4	6.35	R 1/4	0.19	4.82	1/2	12.7	0.77	19.56	1.06	26.92	0.92	23.37	0.60	15.3
TME - 4 - 6P	1/4	6.35	R 3/8	0.19	4.82	11/16	17.5	0.88	22.35	1.17	29.71	1.03	26.16	0.60	15.3
TME - 4 - 8P	1/4	6.35	R 1/2	0.19	4.82	13/16	20.6	0.96	24.38	1.25	31.75	1.30	33.02	0.60	15.3
TME - 5 - 2P	5/16	7.93	R 1/8	0.19	4.82	9/16	14.3	0.84	21.34	1.13	28.70	0.78	19.81	0.64	16.2
TME - 5 - 4P	5/16	7.93	R 1/4	0.25	6.35	9/16	14.3	0.84	21.34	1.13	28.70	0.96	24.38	0.64	16.2
TME - 5 - 6P	5/16	7.93	R 3/8	0.25	6.35	11/16	17.5	0.91	23.11	1.20	30.48	1.03	26.16	0.64	16.2
TME - 6 - 2P	3/8	9.52	R 1/8	0.19	4.82	5/8	15.9	0.91	23.11	1.20	30.48	0.82	20.83	0.66	16.9
TME - 6 - 4P	3/8	9.52	R 1/4	0.28	7.11	5/8	15.9	0.91	23.11	1.20	30.48	1.00	25.40	0.66	16.9
TME - 6 - 6P	3/8	9.52	R 3/8	0.28	7.11	11/16	17.5	0.94	23.87	1.23	31.24	1.03	26.16	0.66	16.9
TME - 6 - 8P	3/8	9.52	R 1/2	0.28	7.11	13/16	20.6	1.02	25.90	1.31	33.28	1.30	33.02	0.66	16.9
TME - 6 - 12P	3/8	9.52	R 3/4	0.28	7.11	1-1/16	27.0	1.17	29.71	1.46	37.08	1.45	36.83	0.66	16.9
TME - 8 - 4P	1/2	12.70	R 1/4	0.28	7.11	13/16	20.6	1.02	25.90	1.42	36.07	1.11	28.19	0.90	22.9
TME - 8 - 6P	1/2	12.70	R 3/8	0.38	9.65	13/16	20.6	1.02	25.90	1.42	36.07	1.11	28.19	0.90	22.9
TME - 8 - 8P	1/2	12.70	R 1/2	0.41	10.41	13/16	20.6	1.02	25.90	1.42	36.07	1.30	33.02	0.90	22.9
TME - 8 - 12P	1/2	12.70	R 3/4	0.41	10.41	1-11/16	27.0	1.17	29.71	1.57	39.88	1.45	36.83	0.90	22.9
TME - 10 - 6P	5/8	15.87	R 3/8	0.38	9.61	15/16	23.8	1.10	27.94	1.50	38.10	1.19	30.23	0.96	24.4
TME - 10 - 8P	5/8	15.87	R 1/2	0.47	11.94	15/16	23.8	1.10	27.94	1.50	38.10	1.38	35.05	0.96	24.4
TME - 10 - 12P	5/8	15.87	R 3/4	0.50	12.70	1-1/16	27.0	1.17	29.71	1.57	39.88	1.45	36.83	0.96	24.4
TME - 12 - 8P	3/4	19.05	R 1/2	0.47	15.74	1-1/16	27.0	1.17	29.71	1.57	39.88	1.45	36.83	0.96	24.5
TME - 12 - 12P	3/4	19.05	R 3/4	0.62	15.74	1-1/16	27.0	1.17	29.71	1.57	39.88	1.45	36.83	0.96	24.5
TME - 14 - 12P	7/8	22.22	R 3/4	0.62	15.74	1-3/16	34.9	1.36	34.54	1.76	44.70	1.64	41.66	1.02	25.9
TME - 16 - 12P	1	25.40	R 3/4	0.62	15.74	1-3/8	34.9	1.45	36.83	1.93	49.02	1.64	41.66	1.23	31.2
TME - 16 - 16P	1	25.4	R 1	0.88	22.35	1-3/8	34.9	1.45	36.83	1.93	49.02	1.83	46.48	1.23	31.2
TME - 20 - 20P	1-1/4	31.75	R 1-1/4	1.09	27.7	1-11/16	42.9	1.75	44.45	2.62	66.5	1.88	47.75	1.62	41.2
TME - 24 - 24P	1-1/2	38.1	R 1-1/2	1.34	34.0	2	50.8	2.0	50.8	3.07	78.0	2.38	60.45	1.97	50.0
TME - 32 - 32P	2	50.8	R 2	1.81	45.97	2-3/4	69.9	2.75	69.85	4.22	107.19	2.78	70.61	2.66	67.6

"D" - Dimension is minimum opening - dimensions are for reference only, and are subject to change without notice.

TUBE FITTINGS |

MALE PIPE WELD 90° ELBOW

TMPWE

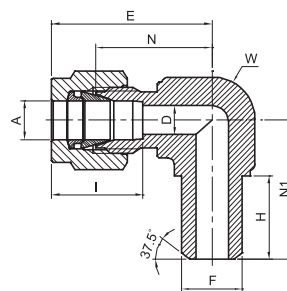

TUBE TO PIPE (INCH)																		
Part Number	A Tube O.D.		F Pipe size		D		W Wrench flat		N		H		E		N1		I	
	in	mm	in	mm	in	mm	in	mm	in	mm	in	mm	in	mm	in	mm	in	mm
TMPWE - 4 - 2TW	1/4	6.35	1/8	10.30	0.19	4.82	1/2	12.7	0.77	19.56	0.38	7.65	1.06	26.92	0.74	18.8	0.60	15.3
TMPWE - 4 - 4TW	1/4	6.35	1/4	13.70	0.19	4.82	1/2	12.7	0.77	19.56	0.56	14.22	1.06	26.92	0.92	23.37	0.60	15.3
TMPWE - 6 - 4TW	3/8	9.52	1/4	13.70	0.28	7.11	5/8	15.9	0.91	23.11	0.56	14.22	1.20	30.48	1.00	25.40	0.66	16.9
TMPWE - 8 - 8TW	1/2	12.70	1/2	21.34	0.41	10.41	13/16	20.6	1.02	25.90	0.75	19.05	1.42	36.06	1.30	33.02	0.90	22.9
TMPWE - 12 - 12TW	3/4	19.05	3/4	26.67	0.62	15.75	1-1/16	27.0	1.17	29.72	0.75	19.05	1.57	39.88	1.45	36.83	0.96	24.5

“D” - Dimension is the minimum opening. These fittings may have a larger opening at the weld end.
The wall thickness of welding edge is based on SCH 80.

TUBE SOCKET WELD 90° ELBOW

TTSWE

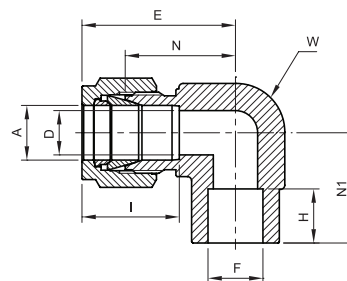

TUBE TO TUBE																		
Part Number	A Tube O.D.		F Pipe size		D		W Wrench flat		N		H		E		N1		I	
	in	mm	in	mm	in	mm	in	mm	in	mm	in	mm	in	mm	in	mm	in	mm
TTSWE - 4 - 4SW	1/4	6.35	1/4	6.35	0.19	4.82	1/2	12.7	0.77	19.60	0.31	7.87	1.06	26.98	0.77	19.60	0.60	15.30
TTSWE - 6 - 6SW	3/8	9.52	3/8	9.52	0.28	7.11	5/8	15.9	0.91	23.11	0.38	9.65	1.20	30.98	0.91	23.11	0.66	16.90
TTSWE - 8 - 8SW	1/2	12.70	1/2	12.70	0.41	10.41	13/16	20.6	1.02	25.90	0.50	12.70	1.42	36.06	1.02	25.90	0.90	22.90
TTSWE - 12 - 12SW	3/4	19.05	3/4	19.05	0.62	15.74	1-1/16	26.98	1.17	29.72	0.56	14.22	1.57	39.87	1.17	29.72	0.96	24.38
TTSWE - 16 - 16SW	1	25.40	1	25.40	0.88	22.35	1-3/8	34.92	1.45	36.83	0.75	19.05	1.93	49.02	1.45	36.83	1.23	31.20

“D” - Dimension is minimum opening - dimensions are for reference only, and are subject to change without notice.

FEMALE 90° ELBOW

TFE

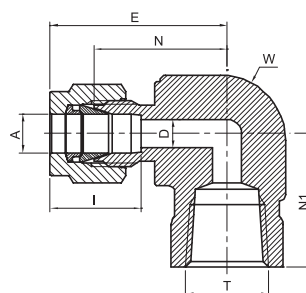

TUBE (METRIC) TO FEMALE NPT THREAD														
Part Number	A Tube O.D.		T NPT	D		W Wrench flat		N		E	N1		I	
	mm	mm	in	mm	mm	in	mm	mm	mm	mm	mm	mm	mm	mm
TFE - 6M - 2N	6	6	1/8	4.8	4.8	1/2	12.7	19.6	19.6	27.0	21.6	21.6	15.3	15.3
TFE - 6M - 4N	6	6	1/4	4.8	4.8	11/16	17.5	22.4	22.4	29.8	22.4	22.4	15.3	15.3
TFE - 6M - 6N	6	6	3/8	4.8	4.8	13/16	20.6	24.4	24.4	31.7	22.4	22.4	15.3	15.3
TFE - 6M - 8N	6	6	1/2	4.8	4.8	1	25.4	27.2	27.2	34.6	28.4	28.4	15.3	15.3
TFE - 8M - 4N	8	8	1/4	6.4	6.4	11/16	17.5	23.1	23.1	30.6	22.4	22.4	16.2	16.2
TFE - 8M - 8N	8	8	1/2	6.4	6.4	1	25.4	28	28	35.2	28.4	28.4	16.2	16.2
TFE - 10M - 2N	10	10	1/8	7.9	7.9	11/16	17.5	23.9	23.9	31.5	21.6	21.6	17.2	17.2
TFE - 10M - 4N	10	10	1/4	7.9	7.9	11/16	17.5	25	25	32.6	22.4	22.4	17.2	17.2
TFE - 10M - 6N	10	10	3/8	7.9	7.9	13/16	20.6	25.9	25.9	33.5	22.4	22.4	17.2	17.2
TFE - 10M - 8N	10	10	1/2	7.9	7.9	1	25.4	28.7	28.7	36.1	28.4	28.4	17.2	17.2
TFE - 12M - 4N	12	12	1/4	9.5	9.5	13/16	20.6	25.9	25.9	36.0	22.4	22.4	22.8	22.8
TFE - 12M - 6N	12	12	3/8	9.5	9.5	13/16	20.6	25.9	25.9	36.0	22.4	22.4	22.8	22.8
TFE - 12M - 8N	12	12	1/2	9.5	9.5	1	25.4	28.7	28.7	38.8	28.4	28.4	22.8	22.8
TFE - 16M - 8N	16	16	1/2	11.9	11.9	1-1/16	27.0	29.7	29.7	39.9	28.4	28.4	22.4	22.4

TUBE (INCH) TO FEMALE NPT THREAD															
Part Number	A Tube O.D.		T NPT	D		W Wrench flat		N		E		N1		I	
	in	mm	in	in	mm	in	mm	in	mm	in	mm	in	mm	in	mm
TFE - 2 - 2N	1/8	3.17	1/8	0.09	2.28	1/2	12.7	0.71	18.03	0.97	24.64	0.75	19.05	0.50	12.7
TFE - 2 - 4N	1/8	3.17	1/4	0.09	2.28	11/16	17.5	0.82	20.80	1.08	27.43	0.94	23.75	0.50	12.7
TFE - 3 - 2N	3/16	4.76	1/8	0.12	30.4	1/2	12.7	0.74	18.80	1.00	25.40	0.75	19.05	0.54	13.7
TFE - 4 - 2N	1/4	6.35	1/8	0.19	4.82	1/2	12.7	0.77	19.55	1.06	26.92	0.75	19.05	0.60	15.3
TFE - 4 - 4N	1/4	6.35	1/4	0.19	7.82	11/16	17.5	0.88	22.40	1.17	29.72	0.88	22.40	0.60	15.3
TFE - 4 - 6N	1/4	6.35	3/8	0.19	7.82	13/16	20.6	0.96	24.38	1.25	31.75	0.88	22.40	0.60	15.3
TFE - 4 - 8N	1/4	6.35	1/2	0.19	7.82	1	25.4	1.07	27.18	1.36	34.54	1.12	28.45	0.60	15.3
TFE - 5 - 2N	5/16	7.93	1/8	0.25	6.35	9/16	14.3	0.84	21.30	1.13	28.70	0.75	19.05	0.64	16.2
TFE - 5 - 4N	5/16	7.93	1/4	0.25	6.35	11/16	17.5	0.91	23.11	1.20	30.48	0.88	22.40	0.64	16.2
TFE - 6 - 2N	3/8	9.52	1/8	0.28	7.11	5/8	15.9	0.91	23.11	1.20	30.48	0.75	19.05	0.66	16.9
TFE - 6 - 4N	3/8	9.52	1/4	0.28	7.11	11/16	17.5	0.88	22.40	1.23	31.24	0.88	22.40	0.66	16.9
TFE - 6 - 6N	3/8	9.52	3/8	0.28	7.11	13/16	20.6	1.02	25.90	1.31	33.27	0.88	22.40	0.66	16.9
TFE - 6 - 8N	3/8	9.52	1/2	0.28	7.11	1	25.4	1.12	28.45	1.42	36.07	1.12	28.45	0.66	16.9
TFE - 8 - 4N	1/2	12.70	1/4	0.41	10.41	13/16	20.6	1.02	25.90	1.42	36.07	0.88	22.40	0.90	22.9
TFE - 8 - 6N	1/2	12.70	3/8	0.41	10.41	13/16	20.6	1.02	25.90	1.42	36.07	0.88	22.40	0.90	22.9
TFE - 8 - 8N	1/2	12.70	1/2	0.41	10.41	1	25.4	1.12	28.44	1.53	38.86	1.13	28.70	0.90	22.9
TFE - 10 - 6N	5/8	15.87	3/8	0.50	12.70	15/16	23.8	1.10	27.90	1.50	38.10	0.88	22.40	0.96	24.4
TFE - 10 - 8N	5/8	15.87	1/2	0.50	12.70	1-1/16	27.0	1.17	29.70	1.57	39.86	1.12	28.45	0.96	24.4
TFE - 12 - 8N	3/4	19.05	1/2	0.62	15.74	1-1/16	27.0	1.17	29.70	1.57	39.86	1.12	28.45	0.96	24.5
TFE - 12 - 12N	3/4	19.05	3/4	0.62	15.74	1-3/8	34.9	1.25	31.75	1.76	44.70	1.25	31.75	0.96	24.5
TFE - 14 - 12N	7/8	22.22	3/4	0.72	18.28	1-3/8	34.9	1.25	31.75	1.76	44.70	1.25	31.75	1.02	25.9
TFE - 16 - 12N	1	25.40	3/4	0.88	22.35	1-3/8	34.9	1.25	31.75	1.93	49.02	1.25	31.75	1.23	31.2
TFE - 16 - 16N	1	25.40	1	0.88	22.35	1-1/16	42.9	1.50	38.10	2.11	53.59	1.50	38.10	1.23	31.2

"D" - Dimension is minimum opening - dimensions are for reference only, and are subject to change without notice.

FEMALE 90° ELBOW

TFE

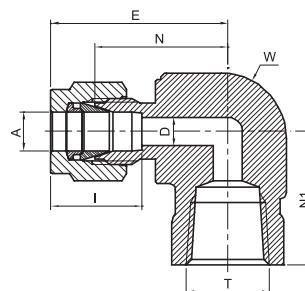

TUBE (METRIC) TO FEMALE ISO TAPERED THREAD														
Part Number	A Tube O.D.		T ISO	D		W Wrench flat		N		E	N1		I	
	mm	in	in	mm	in	mm	in	mm	mm	mm	mm	mm	mm	
TFE - 6M - 2P	6		Rc 1/8	4.8	1/2	12.7		19.6		27		21.6		15.3
TFE - 6M - 4P	6		Rc 1/4	4.8	11/16	17.5		22.4		29.8		22.4		15.3
TFE - 6M - 6P	6		Rc 3/8	4.8	13/16	20.6		24.4		31.7		22.4		15.3
TFE - 6M - 8P	6		Rc 1/2	4.8	1	25.4		27.2		34.6		28.4		15.3
TFE - 8M - 4P	8		Rc 1/4	6.4	11/16	17.5		23.1		30.6		22.4		16.2
TFE - 8M - 8P	8		Rc 1/2	6.4	1	25.4		28		35.2		28.4		16.2
TFE - 10M - 2P	10		Rc 1/8	7.9	11/16	17.5		23.9		31.5		21.6		17.2
TFE - 10M - 4P	10		Rc 1/4	7.9	11/16	17.5		25		32.6		22.4		17.2
TFE - 10M - 6P	10		Rc 3/8	7.9	13/16			25.9		33.5		22.4		17.2
TFE - 10M - 8P	10		Rc 1/2	7.9	1	25.4		28.7		36.1		28.4		17.2
TFE - 12M - 4P	12		Rc 1/4	9.5	13/16	20.6		25.9		36		22.4		22.8
TFE - 12M - 6P	12		Rc 3/8	9.5	13/16	20.6		25.9		36		22.4		22.8
TFE - 12M - 8P	12		Rc 1/2	9.5	1	25.4		28.7		38.8		28.4		22.8
TFE - 16M - 8P	16		Rc 1/2	12.7	1-1/16	27		29.7		39.9		28.4		22.4

TUBE (INCH) TO FEMALE ISO TAPERED THREAD															
Part Number	A Tube O.D.		T ISO	D		W Wrench flat		N		E		N1		I	
	in	mm	in	in	mm	in	mm	in	mm	in	mm	in	mm	in	mm
TFE - 2 - 2P	1/8	3.17	Rc 1/8	0.09	2.28	1/2	12.7	0.71	18.03	0.97	24.64	0.75	19.05	0.50	12.7
TFE - 2 - 4P	1/8	3.17	Rc 1/4	0.09	2.28	11/16	17.5	0.82	20.80	1.08	27.43	0.94	23.75	0.50	12.7
TFE - 3 - 2P	3/16	4.76	Rc 1/8	0.12	30.4	1/2	12.7	0.74	18.80	1.00	25.40	0.75	19.05	0.54	13.7
TFE - 4 - 2P	1/4	6.35	Rc 1/8	0.19	4.82	1/2	12.7	0.77	19.55	1.06	26.92	0.75	19.05	0.60	15.3
TFE - 4 - 4P	1/4	6.35	Rc 1/4	0.19	7.82	11/16	17.5	0.88	22.40	1.17	29.72	0.88	22.40	0.60	15.3
TFE - 4 - 6P	1/4	6.35	Rc 3/8	0.19	7.82	13/16	20.6	0.96	24.38	1.25	31.75	0.88	22.40	0.60	15.3
TFE - 4 - 8P	1/4	6.35	Rc 1/2	0.19	7.82	1	25.4	1.07	27.18	1.36	34.54	1.12	28.45	0.60	15.3
TFE - 5 - 2P	5/16	7.93	Rc 1/8	0.25	6.35	9/16	14.3	0.84	21.30	1.13	28.70	0.75	19.05	0.64	16.2
TFE - 5 - 4P	5/16	7.93	Rc 1/4	0.25	6.35	11/16	17.5	0.91	23.11	1.20	30.48	0.88	22.40	0.64	16.2
TFE - 6 - 2P	3/8	9.52	Rc 1/8	0.28	7.11	5/8	15.9	0.91	23.11	1.20	30.48	0.75	19.05	0.66	16.9
TFE - 6 - 4P	3/8	9.52	Rc 1/4	0.28	7.11	11/16	17.5	0.88	22.40	1.23	31.24	0.88	22.40	0.66	16.9
TFE - 6 - 6P	3/8	9.52	Rc 3/8	0.28	7.11	13/16	20.6	1.02	25.90	1.31	33.27	0.88	22.40	0.66	16.9
TFE - 6 - 8P	3/8	9.52	Rc 1/2	0.28	7.11	1	25.4	1.12	28.45	1.42	36.07	1.12	28.45	0.66	16.9
TFE - 8 - 4P	1/2	12.70	Rc 1/4	0.41	10.41	13/16	20.6	1.02	25.90	1.42	36.07	0.88	22.40	0.90	22.9
TFE - 8 - 6P	1/2	12.70	Rc 3/8	0.41	10.41	13/16	20.6	1.02	25.90	1.42	36.07	0.88	22.40	0.90	22.9
TFE - 8 - 8P	1/2	12.70	Rc 1/2	0.41	10.41	1	25.4	1.12	28.44	1.53	38.86	1.13	28.70	0.90	22.9
TFE - 10 - 6P	5/8	15.87	Rc 3/8	0.50	12.70	15/16	23.8	1.10	27.90	1.50	38.10	0.88	22.40	0.96	24.4
TFE - 10 - 8P	5/8	15.87	Rc 1/2	0.50	12.70	1-1/16	27.0	1.17	29.70	1.57	39.86	1.12	28.45	0.96	24.4
TFE - 12 - 8P	3/4	19.05	Rc 1/2	0.62	15.74	1-1/16	27.0	1.17	29.70	1.57	39.86	1.12	28.45	0.96	24.5
TFE - 12 - 12P	3/4	19.05	Rc 3/4	0.62	15.74	1-3/8	34.9	1.25	31.75	1.76	44.70	1.25	31.75	0.96	24.5
TFE - 14 - 12P	7/8	22.22	Rc 3/4	0.72	18.28	1-3/8	34.9	1.25	31.75	1.76	44.70	1.25	31.75	1.02	25.9
TFE - 16 - 12P	1	25.40	Rc 3/4	0.88	22.35	1-3/8	34.9	1.25	31.75	1.93	49.02	1.25	31.75	1.23	31.2
TFE - 16 - 16P	1	25.40	Rc 1	0.88	22.35	1-1/16	42.9	1.50	38.10	2.11	53.59	1.50	38.10	1.23	31.2

"D" - Dimension is minimum opening - dimensions are for reference only, and are subject to change without notice.

ADJUSTABLE ELBOW

TAE

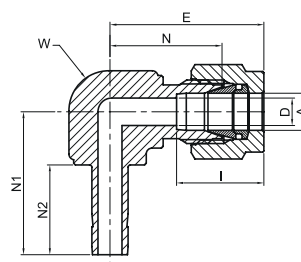

TUBE(METRIC) TO STUB(METRIC)											
Part Number	A Tube O.D.		D		W Wrench flat		N	E	N1	N2	I
	mm	mm	mm	mm	mm	mm	mm	mm	mm	mm	mm
TAE - 3M	3	1.9	9.5	15.7	22.3	20.5	13.5	12.9			
TAE - 4M	4	2.2	12.7	18.8	25.4	23.0	14.2	13.7			
TAE - 6M	6	4.1	12.7	19.6	27.0	25.0	15.7	15.3			
TAE - 8M	8	5.6	14.3	21.3	28.8	27.2	16.9	16.2			
TAE - 10M	10	7.1	17.5	23.9	31.5	29.5	17.6	17.2			
TAE - 12M	12	8.8	20.6	25.9	36.0	37.3	23.3	22.8			
TAE - 15M	15	11.2	23.8	28.7	38.8	41.6	24.7	24.4			
TAE - 16M	16	12.0	23.8	28.7	38.8	41.8	24.7	24.4			
TAE - 18M	18	13.9	27.0	28.7	39.8	42.6	24.7	24.4			
TAE - 20M	20	15.5	30.0	32.5	42.6	67.1	26.6	26.0			

TUBE(INCH) TO TUBE(INCH)											
Part Number	A Tube O.D.		D		W Wrench flat		N	E	N1	N2	I
	mm	mm	mm	mm	mm	mm	mm	mm	mm	mm	mm
TAE - 1	1/16	1.58	0.76	3/8	9.52	14.00	22.3	16.00	8.9	8.6	
TAE - 2	1/8	3.17	2.03	3/8	9.52	15.74	22.3	20.59	13.5	12.7	
TAE - 3	3/16	4.76	3.04	1/2	12.70	17.78	25.4	22.48	14.2	13.7	
TAE - 4	1/4	6.35	4.32	1/2	12.70	19.55	27.0	25.00	15.7	15.32	
TAE - 5	5/16	7.93	5.59	9/16	14.28	21.33	28.8	27.08	16.9	16.3	
TAE - 6	3/8	9.52	6.86	5/8	15.87	23.11	31.5	26.00	17.5	16.9	
TAE - 8	1/2	12.70	9.40	13/16	20.63	25.90	36.0	37.30	23.3	22.9	
TAE - 10	5/8	15.87	11.94	15/16	23.80	28.70	38.8	41.75	24.7	24.4	
TAE - 12	3/4	19.05	14.73	1-1/16	26.98	29.71	38.8	42.60	24.7	24.5	
TAE - 14	7/8	22.22	18.28	1-3/16	30.00	34.54	39.8	49.39	26.6	25.9	
TAE - 16	1	25.40	20.32	1-3/8	34.92	36.83	42.6	55.60	33	31.2	

"D" - Dimension is minimum opening - dimensions are for reference only, and are subject to change without notice.

MALE RUN TEE

TMRT

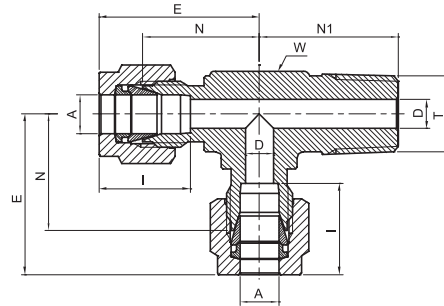
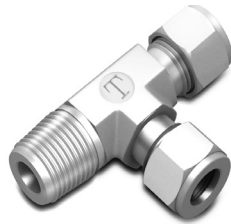

TUBE (METRIC) TO MALE NPT THREAD

Part Number	A Tube O.D.		T NPT	D		W Wrench flat		N		E	N1		I
	mm	in	in	mm	in	mm	in	mm	mm	mm	mm	mm	
TMRT - 3M - 2N	3		1/8	2.4		1/2		12.7		17.0		17.8	12.9
TMRT - 3M - 4N	3		1/4	2.4		1/2		12.7		18.0		23.4	12.9
TMRT - 4M - 2N	4		1/8	2.4		1/2		12.7		18.8		18.8	13.7
TMRT - 6M - 2N	6		1/8	4.8		1/2		12.7		19.6		18.8	15.3
TMRT - 6M - 4N	6		1/4	4.8		1/2		12.7		19.6		23.4	15.3
TMRT - 8M - 2N	8		1/8	4.8		5/8		15.9		22.4		20.8	16.2
TMRT - 8M - 4N	8		1/4	6.4		5/8		15.9		22.4		25.4	16.2
TMRT - 10M - 4N	10		1/4	7.1		13/16		20.6		25.9		28.2	17.2
TMRT - 10M - 6N	10		3/8	7.9		11/16		17.5		23.9		28.2	17.2
TMRT - 12M - 4N	12		1/4	7.1		13/16		20.6		25.9		28.2	22.8
TMRT - 12M - 6N	12		3/8	9.5		13/16		20.6		25.9		28.2	22.8
TMRT - 12M - 8N	12		1/2	9.5		13/16		20.6		25.9		33.0	22.8
TMRT - 16M - 6N	16		3/8	9.5		15/16		23.8		27.9		30.2	24.4
TMRT - 16M - 8N	16		1/2	11.9		15/16		23.8		27.9		35.1	24.4
TMRT - 20M - 12N	20		3/4	15.9		1-3/8		34.9		34.5		41.7	26.0

TUBE (INCH) TO MALE NPT THREAD

Part Number	A Tube O.D.		T NPT	D		W Wrench flat		N		E		N1		I	
	in	mm	in	in	mm	in	mm	in	mm	in	mm	in	mm	in	mm
TMRT - 2 - 2N	1/8	3.17	1/8	0.09	2.28	7/16	11.1	0.67	17.02	0.93	23.62	0.70	17.78	0.50	12.7
TMRT - 2 - 4N	1/8	3.17	1/4	0.09	2.28	1/2	12.7	0.71	18.03	0.97	24.64	0.92	23.40	0.50	12.7
TMRT - 3 - 2N	3/16	4.76	1/8	0.12	3.05	7/16	11.1	0.70	17.78	0.96	24.38	0.70	17.78	0.54	13.7
TMRT - 4 - 2N	1/4	6.35	1/8	0.19	4.82	1/2	12.7	0.77	19.56	1.06	26.92	0.74	18.80	0.60	15.3
TMRT - 4 - 4N	1/4	6.35	1/4	0.19	4.82	1/2	12.7	0.77	19.56	1.06	26.92	0.92	23.37	0.60	15.3
TMRT - 5 - 2N	5/16	7.93	1/8	0.19	4.82	5/8	15.9	0.88	22.35	1.17	29.71	0.82	20.83	0.64	16.2
TMRT - 6 - 4N	3/8	9.52	1/4	0.28	7.11	5/8	15.9	0.91	23.11	1.20	30.48	1.00	25.40	0.66	16.9
TMRT - 6 - 6N	3/8	9.52	3/8	0.28	7.11	13/16	20.6	1.02	25.91	1.31	33.27	1.11	28.19	0.66	16.9
TMRT - 8 - 6N	1/2	12.70	3/8	0.38	9.50	13/16	20.6	1.02	25.91	1.42	36.07	1.11	28.19	0.90	22.9
TMRT - 8 - 8N	1/2	12.70	1/2	0.41	10.41	13/16	20.6	1.02	25.91	1.42	36.07	1.30	33.00	0.90	22.9
TMRT - 10 - 8N	5/8	15.87	1/2	0.47	11.94	15/16	23.8	1.10	27.94	1.50	38.10	1.38	35.05	0.96	24.4
TMRT - 12 - 12N	3/4	19.05	3/4	0.62	15.75	1-1/16	27.0	1.17	29.72	1.57	39.88	1.45	36.83	0.96	24.5

"D" - Dimension is minimum opening - dimensions are for reference only, and are subject to change without notice.

FEMALE RUN TEE

TFRT

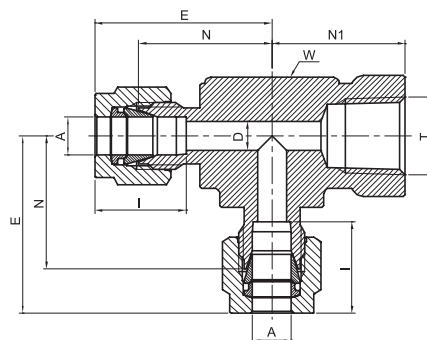

TUBE (METRIC) TO FEMALE NPT THREAD										
Part Number	A Tube O.D.		T NPT	D	W Wrench flat		N	E	N1	I
	mm	in	in	mm	in	mm	mm			mm
TFRT - 6M - 2N	6		1/8	4.8	1/2	12.7	19.6	27.0	19.0	15.3
TFRT - 6M - 4N	6		1/4	4.8	11/16	17.5	22.4	29.8	22.4	15.3
TFRT - 6M - 8N	6		1/2	4.8	1	25.4	27.2	34.5	28.4	15.3
TFRT - 8M - 2N	8		1/8	6.4	5/8	15.9	22.4	29.9	19.0	16.2
TFRT - 8M - 4N	8		1/4	6.4	11/16	17.5	23.1	30.6	22.4	16.2
TFRT - 8M - 6N	8		3/8	6.4	13/16	20.6	25.2	32.4	22.4	16.2
TFRT - 8M - 8N	8		1/2	6.4	1	25.4	28	35.2	28.4	16.2
TFRT - 10M - 4N	10		1/4	7.9	11/16	17.5	25	32.6	22.4	17.2
TFRT - 12M - 4N	12		1/4	9.5	13/16	20.6	25.9	36.0	22.4	22.8
TFRT - 12M - 6N	12		3/8	9.5	13/16	20.6	25.9	36.0	22.4	22.8
TFRT - 12M - 8N	12		1/2	9.5	1	25.4	28.7	38.8	28.4	22.8
TFRT - 16M - 8N	16		1/2	12.7	1	25.4	29.7	39.5	28.4	24.4

TUBE (INCH) TO FEMALE NPT THREAD															
Part Number	A Tube O.D.		T NPT	D		W Wrench flat		N		E		N1		I	
	in	mm	in	in	mm	in	mm	in	mm	in	mm	in	mm	in	mm
TFRT - 2 - 2N	1/8	3.17	1/8	0.09	2.28	1/2	12.70	0.71	18.00	0.97	24.44	0.75	19.05	0.50	12.70
TFRT - 4 - 2N	1/4	6.35	1/8	0.19	4.82	1/2	12.70	0.77	19.55	1.06	26.92	0.75	19.05	0.60	15.30
TFRT - 4 - 4N	1/4	6.35	1/4	0.19	4.82	11/16	17.50	0.88	22.35	1.17	29.71	0.88	22.35	0.60	15.30
TFRT - 6 - 4N	3/8	9.52	1/4	0.28	7.11	11/16	17.50	0.94	23.87	1.23	31.24	0.88	22.35	0.60	16.90
TFRT - 8 - 6N	1/2	12.70	3/8	0.41	10.41	13/16	20.60	1.02	25.90	1.42	36.07	0.88	22.35	0.90	22.90
TFRT - 8 - 8N	1/2	12.70	1/2	0.41	10.41	1-1/16	27.00	1.17	29.72	1.57	39.88	1.12	28.45	0.90	22.90
TFRT - 12 - 12N	3/4	19.05	3/4	0.62	15.75	1-3/8	34.90	1.36	34.54	1.76	44.70	1.25	31.75	0.90	24.50
TFRT - 16 - 12N	1	25.40	3/4	19.05	22.35	1-3/8	34.90	1.45	36.83	1.93	49.02	1.25	31.75	1.23	31.24
TFRT - 16 - 16N	1	25.40	1	25.40	22.35	1-11/16	42.86	1.63	41.40	2.11	53.59	1.50	38.10	1.23	31.24

"D" - Dimension is minimum opening - dimensions are for reference only, and are subject to change without notice.

MALE BRANCH TEE

TMBT

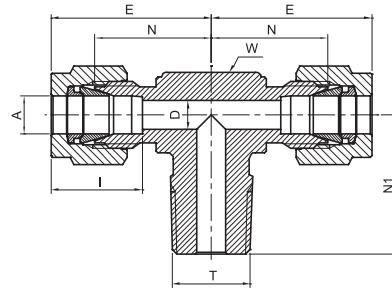

TUBE (METRIC) TO MALE NPT THREAD

Part Number	A Tube O.D.		T NPT	D		W Wrench flat		N		E		N1		I		
	mm	in	in	mm	in	mm	in	mm	in	mm	in	mm	in	mm	in	
TMBT - 3M - 2N	3		1/8	2.4		1/2		12.7		17.0		23.6		17.8		12.9
TMBT - 3M - 4N	3		1/4	2.4		1/2		12.7		18.0		24.6		23.4		12.9
TMBT - 4M - 2N	4		1/8	2.4		1/2		12.7		18.8		25.4		18.8		13.7
TMBT - 6M - 2N	6		1/8	4.8		1/2		12.7		19.6		27.0		18.8		15.3
TMBT - 6M - 4N	6		1/4	4.8		1/2		12.7		19.6		27.0		23.4		15.3
TMBT - 8M - 2N	8		1/8	4.8		5/8		15.9		22.4		29.9		20.8		16.2
TMBT - 8M - 4N	8		1/4	6.4		5/8		15.9		22.4		29.9		25.4		16.2
TMBT - 10M - 4N	10		1/4	7.1		13/16		20.6		25.9		33.5		28.2		17.2
TMBT - 10M - 6N	10		3/8	7.9		11/16		17.5		23.9		31.5		28.2		17.2
TMBT - 12M - 4N	12		1/4	7.1		13/16		20.6		25.9		36.0		28.2		22.8
TMBT - 12M - 6N	12		3/8	9.5		13/16		20.6		25.9		36.0		28.2		22.8
TMBT - 12M - 8N	12		1/2	9.5		13/16		20.6		25.9		36.0		33.0		22.8
TMBT - 16M - 6N	16		3/8	9.5		15/16		23.8		27.9		38.0		30.2		24.4
TMBT - 16M - 8N	16		1/2	11.9		15/16		23.8		27.9		38.0		35.1		24.4
TMBT - 20M - 12N	20		3/4	15.9		1-3/8		34.9		34.5		44.6		41.7		26.0

TUBE (INCH) TO MALE NPT THREAD

Part Number	A Tube O.D.		T NPT	D		W Wrench flat		N		E		N1		I	
	in	mm	in	in	mm	in	mm	in	mm	in	mm	in	mm	in	mm
TMBT - 2 - 2N	1/8	3.17	1/8	0.09	2.28	7/16	11.1	0.67	17.02	0.93	23.62	0.70	17.78	0.50	12.7
TMBT - 2 - 4N	1/8	3.17	1/4	0.09	2.28	1/2	12.7	0.71	18.03	0.97	24.64	0.92	23.37	0.50	12.7
TMBT - 3 - 2N	3/16	4.76	1/8	0.12	3.04	7/16	11.1	0.70	17.78	0.96	24.38	0.70	17.78	0.54	13.7
TMBT - 4 - 2N	1/4	6.35	1/8	0.19	4.82	1/2	12.7	0.77	19.56	1.06	26.90	0.74	18.80	0.60	15.3
TMBT - 4 - 4N	1/4	6.35	1/4	0.19	4.82	1/2	12.7	0.77	19.56	1.06	26.90	0.92	23.87	0.60	15.3
TMBT - 5 - 2N	5/16	7.93	1/8	0.19	4.82	5/8	15.9	0.88	22.35	1.17	29.71	0.82	20.83	0.64	16.2
TMBT - 6 - 4N	3/8	9.52	1/4	0.28	7.11	5/8	15.9	0.91	23.11	1.20	30.48	1.00	25.40	0.66	16.9
TMBT - 6 - 6N	3/8	9.52	3/8	0.28	7.11	13/16	20.6	1.02	25.91	1.31	33.27	1.11	28.19	0.66	16.9
TMBT - 8 - 6N	1/2	12.70	3/8	0.38	9.65	13/16	20.6	1.02	25.91	1.42	36.07	1.11	28.19	0.90	22.9
TMBT - 8 - 8N	1/2	12.70	1/2	0.41	10.41	13/16	20.6	1.02	25.96	1.42	36.07	1.30	33.02	0.90	22.9
TMBT - 10 - 8N	5/8	15.87	1/2	0.47	11.94	1	25.4	1.13	28.70	1.53	38.86	1.41	35.80	0.96	24.4
TMBT - 12 - 12N	3/4	19.05	3/4	0.62	15.75	1-1/16	27.0	1.17	29.72	1.57	39.88	1.45	36.83	0.96	24.5

"D" - Dimension is minimum opening - dimensions are for reference only, and are subject to change without notice.

FEMALE BRANCH TEE

TFBT

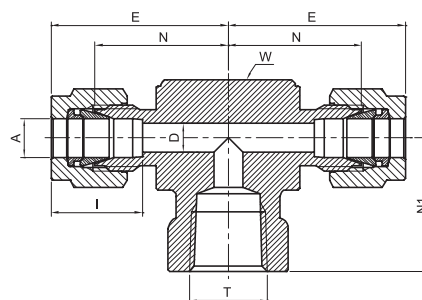

TUBE (METRIC) TO FEMALE NPT THREAD													
Part Number	A Tube O.D.		T NPT	D		W Wrench flat		N		E	N1		I
	mm	in	in	mm	in	mm	in	mm	mm	mm	mm	mm	
TFBT - 6M - 2N	6		1/8	4.8		1/2		12.7		19.6	27.0	19.0	15.3
TFBT - 6M - 4N	6		1/4	4.8		11/16		17.5		22.4	29.8	22.4	15.3
TFBT - 6M - 6N	6		3/8	4.8		13/16		20.6		24.4	31.7	22.4	15.3
TFBT - 6M - 8N	6		1/2	4.8		1		25.4		27.2	34.5	28.4	15.3
TFBT - 8M - 2N	8		1/8	6.4		5/8		15.9		23.1	29.9	19.0	16.2
TFBT - 8M - 4N	8		1/4	6.4		11/16		17.5		23.1	30.6	22.4	16.2
TFBT - 8M - 6N	8		3/8	6.4		13/16		20.6		25.2	32.4	22.4	16.2
TFBT - 8M - 8N	8		1/2	6.4		1		25.4		28.0	35.2	28.4	16.2
TFBT - 10M - 4N	10		1/4	7.9		13/16		20.6		25.9	33.5	22.4	17.2
TFBT - 10M - 6N	10		3/8	7.9		13/16		20.6		25.9	33.5	22.4	17.2
TFBT - 10M - 8N	10		1/2	7.9		1		25.4		28.7	36.1	22.4	17.2
TFBT - 12M - 4N	12		1/4	9.5		13/16		20.6		25.9	36.0	22.4	22.8
TFBT - 12M - 6N	12		3/8	9.5		13/16		20.6		25.9	36.0	22.4	22.8
TFBT - 12M - 8N	12		1/2	9.5		1		25.4		28.7	38.8	28.4	22.8
TFBT - 16M - 8N	16		1/2	12.7		1		25.4		28.7	38.8	28.4	24.4

TUBE (INCH) TO FEMALE NPT THREAD															
Part Number	A Tube O.D.		T NPT	D		W Wrench flat		N		E		N1		I	
	in	mm	in	in	mm	in	mm	in	mm	in	mm	in	mm	in	mm
TFBT - 2 - 2N	1/8	3.17	1/8	0.09	2.28	1/2	12.7	0.70	18.00	0.97	24.64	0.75	19.05	0.50	12.7
TFBT - 4 - 2N	1/4	6.35	1/8	0.19	4.82	1/2	12.7	0.77	19.56	1.06	26.96	0.75	19.05	0.60	15.3
TFBT - 4 - 4N	1/4	6.35	1/4	0.19	4.82	11/16	17.5	0.88	22.35	1.17	29.71	0.88	22.35	0.60	15.3
TFBT - 6 - 4N	3/8	9.52	1/4	0.28	7.11	11/16	17.5	0.94	23.88	1.23	31.24	0.88	22.35	0.66	16.9
TFBT - 8 - 4N	1/2	12.70	1/4	0.41	10.41	13/16	20.6	1.02	25.90	1.42	36.07	0.88	22.35	0.90	22.9
TFBT - 8 - 6N	1/2	12.70	3/8	0.41	10.41	13/16	20.6	1.02	25.90	1.42	36.07	0.88	22.35	0.90	22.9
TFBT - 8 - 8N	1/2	12.70	1/2	0.41	10.41	1-1/8	25.4	25.4	28.70	1.53	38.86	1.12	28.45	0.90	22.9
TFBT - 10 - 8N	5/8	15.87	1/2	0.50	12.70	1-1/8	25.4	25.4	28.70	1.53	38.86	1.12	28.44	0.96	24.4
TFBT - 12 - 12N	3/4	19.05	3/4	0.62	15.74	1-3/8	34.9	1.36	34.50	1.76	44.70	1.25	31.75	0.96	24.5
TFBT - 16 - 12N	1	25.40	3/4	0.88	22.35	1-3/8	34.9	1.45	36.83	1.93	49.02	1.25	31.75	1.23	31.2
TFBT - 16 - 16N	1	25.40	1	0.88	22.35	1-11/16	42.9	1.63	41.40	2.11	53.60	1.50	38.10	1.23	31.2

"D" - Dimension is minimum opening - dimensions are for reference only, and are subject to change without notice.

BULKHEAD UNION

TBU

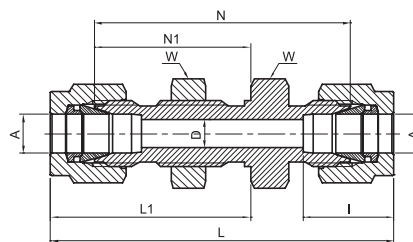

TUBE (METRIC) TO TUBE (METRIC)

Part Number	A Tube O.D.		D		W Hex. flat		N		N1		L		L1		I		Panel hole drill size	Max. panel thickness
	mm	mm	mm	mm	mm	mm	mm	mm	mm	mm	mm	mm	mm	mm	mm			
TBU - 3M	3		2.4		14		38.1		24.6		51.3		31.2		12.9		8.3	12.7
TBU - 4M	4		2.4		14		40.4		25.4		53.6		32.0		13.7		9.9	12.7
TBU - 6M	6		4.8		16		42.9		26.2		57.7		33.6		15.3		11.5	10.2
TBU - 8M	8		6.4		18		46		28.6		61.0		36.1		16.2		13.1	11.2
TBU - 10M	10		7.9		22		48.5		29.4		63.7		37.0		17.2		16.25	11.2
TBU - 12M	12		9.5		24		50.8		31.8		71.0		41.9		22.8		19.5	12.7
TBU - 15M	15		11.9		27		52.3		32.5		72.5		42.6		24.4		22.8	12.7
TBU - 16M	16		12.7		27		52.3		32.5		72.5		42.6		24.4		22.8	12.7
TBU - 18M	18		15.1		30		58.7		37.3		78.9		47.4		24.4		26.0	16.8
TBU - 20M	20		15.9		35		64.3		42.9		84.5		53.0		26.0		29.0	23.9
TBU - 22M	22		18.3		35		64.3		42.9		84.5		53.0		26.0		29.0	19.1
TBU - 25M	25		21.8		41		71.4		45.2		95.9		57.5		31.3		33.7	19.0
TBU - 32M	32		28.6		50		82.3		49.5		128.3		72.5		42.0		42.5	19.0
TBU - 38M	38		33.7		60		89.4		51.5		144.6		79.1		49.4		50.5	19.0

TUBE (INCH) TO TUBE (INCH)

Part Number	A Tube O.D.		D		W Hex. flat		N		N1		L		L1		I		Panel hole drill size	Max. panel thickness		
	in	mm	in	mm	in	mm	in	mm	in	mm	in	mm	in	mm	in	mm				
	TBU - 1	1/16	1.58	0.05	1.27	5/16	7.9	0.94	23.88	0.53	13.46	1.24	31.5	0.68	17.3	0.34			8.6	13/64
TBU - 2	1/8	3.17	0.09	2.28	1/2	12.7	1.5	38.1	0.97	24.63	2.02	51.3	1.23	31.24	0.5	12.7	21/64	8.33	0.5	12.7
TBU - 3	3/16	4.76	0.12	3.04	9/16	14.3	1.59	40.38	1	25.4	2.11	53.59	1.26	32	0.54	13.7	25/64	9.92	0.5	12.7
TBU - 4	1/4	6.35	0.19	4.82	5/8	15.9	1.69	42.92	1.03	26.16	2.27	57.65	1.32	33.52	0.6	15.3	29/64	11.5	0.4	10.16
TBU - 5	5/16	7.93	0.25	6.35	11/16	17.5	1.81	45.97	1.12	28.44	2.39	60.7	1.41	35.81	0.64	16.2	33/64	13.09	0.44	11.17
TBU - 6	3/8	9.52	0.28	7.11	3/4	19.1	1.87	47.5	1.16	29.46	2.45	62.2	1.45	36.83	0.66	16.9	37/64	14.68	0.44	11.17
TBU - 8	1/2	12.7	0.41	10.41	15/16	23.8	2	50.2	1.25	31.75	2.8	71.12	1.65	41.91	0.9	22.9	49/64	19.44	0.5	12.7
TBU - 10	5/8	15.87	0.5	12.7	1-1/16	27	2.06	52.32	1.28	32.51	2.86	72.64	1.68	42.67	0.96	24.4	57/64	22.62	0.5	12.7
TBU - 12	3/4	19.05	0.62	15.9	1-3/16	30.2	2.31	58.67	1.47	37.33	3.11	78.99	1.87	47.49	0.96	24.5	1-1/64	25.79	0.66	16.76
TBU - 16	1	25.4	0.88	22.35	1-5/8	41.3	2.81	71.37	1.78	45.21	3.77	95.76	2.26	57.4	1.23	31.2	1-21/64	33.73	0.75	19.05
TBU - 20	1-1/4	31.75	1.09	27.7	1-7/8	47.6	3.11	79	1.88	47.75	4.85	123.19	2.75	69.85	1.62	41.2	1-41/64	41.67	0.75	19.05
TBU - 24	1-1/2	38.1	1.34	34	2-1/4	57.2	3.34	84.8	1.94	49.28	5.48	139.19	3.01	76.45	1.97	50	1-61/64	49.61	0.75	19.05
TBU - 32	2	50.8	1.81	45.97	2-3/4	69.9	4.16	105.66	2.22	56.39	7.1	180.34	3.69	93.73	2.66	67.6	2-41/64	67.07	0.75	19.05

"D" - Dimension is minimum opening - dimensions are for reference only, and are subject to change without notice.

BULKHEAD FEMALE CONNECTOR

TBFC

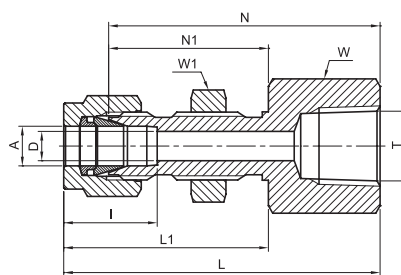

TUBE (INCH) TO MALE NPT THREAD																							
Part Number	A Tube O.D.		T	D		W Hex. flat		W1 Hex. flat		N		N1		L		L1		I		Panel hole drill size		Max. panel thickness	
	in	mm	in	in	mm	in	mm	in	mm	in	mm	in	mm	in	mm	in	mm	in	mm	in	mm	in	mm
TBFC - 2 - 2N	1/8	3.17	1/8	.09	2.28	9/16	14.3	1/2	12.7	1.50	38.10	0.97	24.63	1.76	44.70	1.23	31.24	0.50	12.7	21/64	8.33	0.50	12.70
TBFC - 4 - 2N	1/4	6.35	1/8	.19	4.82	5/8	15.9	5/8	15.9	1.56	39.62	1.03	26.16	1.85	46.99	1.32	33.52	0.60	15.3	29/64	11.50	0.40	10.16
TBFC - 4 - 4N	1/4	6.35	1/4	.19	4.82	3/4	19.1	5/8	15.9	1.75	44.45	1.03	26.16	2.04	51.81	1.32	33.52	0.60	15.3	29/64	11.50	0.40	10.16
TBFC - 6 - 4N	3/8	9.52	1/4	.28	7.11	3/4	19.1	3/4	19.1	1.88	47.75	1.16	29.46	2.17	55.11	1.45	36.83	0.66	16.9	37/64	14.68	0.44	11.17
TBFC - 8 - 6N	1/2	12.70	3/8	.41	10.41	15/16	23.8	15/16	23.8	2.03	51.56	1.25	31.75	2.43	61.72	1.65	41.91	0.90	22.9	49/64	19.44	0.50	12.70
TBFC - 8 - 8N	1/2	12.70	1/2	.41	10.41	1-1/16	27.0	15/16	23.8	2.22	56.38	1.25	31.75	2.62	66.54	1.65	41.91	0.90	22.9	49/64	19.44	0.50	12.70
TBFC - 12 - 12N	3/4	19.05	3/4	.62	15.74	15/16	23.81	1-5/16	33.33	2.50	63.60	1.51	38.30	2.89	73.51	2.89	47.21	0.96	24.38	1-1/64	25.79	0.66	16.76

BULKHEAD REDUCER

TBR

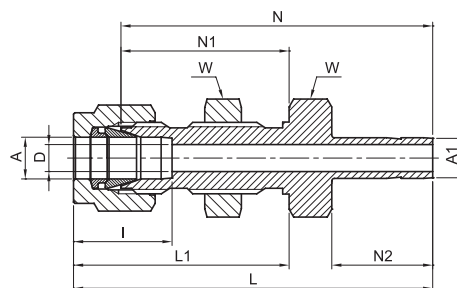

TUBE (INCH) TO SUB (INCH)																				
Part Number	A Tube O.D.		A1 Tube O.D.	D		W Hex. flat		N		N1		N2		L		L1		I		
	in	mm	in	in	mm	in	mm	in	mm	in	mm	in	mm	in	mm	in	mm	in	mm	
TBR - 2	1/8	3.17	1/8	0.08	2.03	1/2	12.70	1.69	42.92	0.97	24.63	0.53	13.46	1.95	49.53	1.23	31.24	0.50	12.7	
TBR - 4	1/4	6.35	1/4	0.17	4.20	5/8	15.90	1.91	48.50	1.03	26.16	0.62	15.74	2.20	55.88	1.32	33.52	0.60	15.3	
TBR - 6	3/8	9.52	3/8	0.28	7.11	3/4	19.10	2.12	53.85	1.16	29.46	0.69	17.52	2.41	61.21	1.45	36.83	0.66	16.9	
TBR - 8	1/2	12.70	1/2	0.39	9.90	15/16	23.80	2.47	62.73	1.25	31.75	0.91	23.11	2.87	72.89	1.65	41.91	0.90	22.9	
TBR - 12	3/4	19.05	3/4	0.62	15.90	1-3/16	26.93	2.81	71.45	1.47	37.33	0.97	24.70	3.21	81.53	1.87	47.49	0.96	24.5	
TBR - 16	1	25.40	1	0.88	22.35	1-5/8	41.27	3.47	88.13	1.78	45.21	1.30	33.00	3.95	100.33	2.26	57.40	1.23	31.2	

"D" - Dimension is minimum opening - dimensions are for reference only, and are subject to change without notice.

TUBE FITTINGS |

BULKHEAD MALE CONNECTOR

TBMC

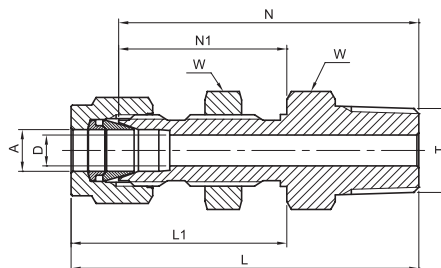

TUBE (METRIC) TO MALE NPT THREAD											
Part Number	A Tube O.D.		T NPT	D	W Hex. flat	N	N1	L	L1	Panel hole drill size	Max. panel thickness
	mm	in	in	mm	mm	mm	mm	mm	mm	mm	mm
TBMC - 6M - 2N	6	1/8	1/8	4.8	16	42.2	26.2	49.6	33.6	11.5	10.2
TBMC - 6M - 4N	6	1/4	1/4	4.8	16	46.2	26.2	53.6	33.6	11.5	10.2
TBMC - 12M - 8N	12	1/2	1/2	9.5	24	58.7	31.8	68.8	41.9	19.5	12.7

15.74 TUBE (INCH) TO MALE NPT THREAD																			
Part Number	A Tube O.D.		T NPT	D		W Hex. flat		N		N1		L		L1		Panel hole drill size		Max. panel thickness	
	in	mm	in	in	mm	in	mm	in	mm	in	mm	in	mm	in	mm	in	mm	in	mm
TBMC - 2 - 2N	1/8	3.17	1/8	0.09	2.28	1/2	12.7	1.57	39.90	0.97	24.60	1.83	46.48	1.23	31.24	21/64	8.33	0.50	12.70
TBMC - 4 - 2N	1/4	6.35	1/8	0.19	4.82	5/8	15.9	1.66	12.20	1.03	26.20	1.95	49.53	1.32	33.52	29/64	11.50	0.40	10.16
TBMC - 4 - 4N	1/4	6.35	1/4	0.19	4.82	5/8	15.9	1.84	46.70	1.03	26.16	2.13	54.10	1.32	33.52	29/64	11.50	0.40	10.16
TBMC - 6 - 4N	3/8	9.52	1/4	0.28	7.11	3/4	19.1	1.97	50.00	1.16	29.46	2.26	57.40	1.45	36.83	37/64	14.68	0.44	11.17
TBMC - 8 - 6N	1/2	12.70	3/8	0.40	10.40	15/16	23.8	2.09	53.10	1.25	31.75	2.49	63.25	1.65	41.91	49/64	19.44	0.50	12.70
TBMC - 8 - 8N	1/2	12.70	1/2	0.40	10.40	15/16	23.8	2.31	58.70	1.25	31.70	2.71	68.83	1.65	41.91	49/64	19.44	0.50	12.70
TBMC - 12 - 12N	3/4	19.05	3/4	0.62	15.74	1-3/16	30.16	2.60	66.04	1.47	37.33	3.00	76.20	1.87	47.49	1-1/64	25.76	0.66	16.76
TBMC - 16 - 16N	1	25.40	1	0.88	22.35	1-5/8	41.27	3.19	81.02	1.78	45.21	3.67	93.21	2.26	57.40	1-21/64	33.73	0.75	19.05

BULKHEAD RETAINER

TBRE

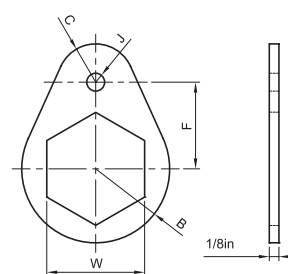
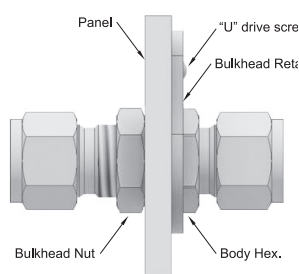

Part Number	Tube O.D.		F	W	B	C	J	Drill Hole Dia	"U" Drive Screw	Drill Number
	in	mm								
TBRE - 1	1/16	-	9.52	7.93	7.93	3.97	3.97	3.0	6-3/8	31
TBRE - 2	1/8	-	12.70	12.70	10.32	5.56				
TBRE - 3	3/16	3, 4	14.28	14.28	11.91	6.35				
TBRE - 4	1/4	6	15.87	15.87	12.70	7.14				
TBRE - 5	5/16	-	17.46	17.46	14.28	7.93				
TBRE - 6	3/8	-	19.05	19.05	15.87	8.73				
TBRE - 8	1/2	12	23.81	23.81	19.05	10.32	5.56	3.66	10-1/2	27
TBRE - 10	5/8	15, 16	25.40	26.98	20.64	10.23				
TBRE - 12	3/4	18	26.98	30.16	23.02	11.91				
TBRE - 14	7/8	20	30.20	34.93	27.80	13.49				
TBRE - 16	1	-	32.54	41.27	29.37	13.49				

"D" - Dimension is minimum opening - dimensions are for reference only, and are subject to change without notice.

UNION CROSS

TUC

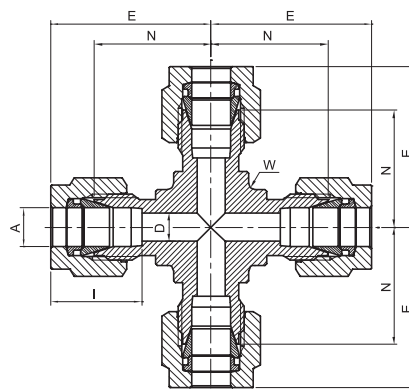
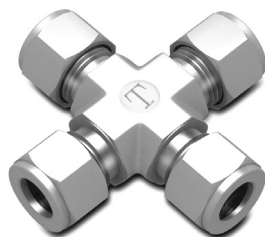

ALL TUBES (METRIC)												
Part Number	A Tube O.D.		D		W Wrench flat		N		E		I	
	mm	mm	mm	mm	in	mm	mm	mm	mm	mm	mm	mm
TUC - 3M	3	3	2.4	2.4	3/8	9.5	15.7	15.7	22.3	22.3	12.9	12.9
TUC - 6M	6	6	4.8	4.8	1/2	12.7	19.6	19.6	27.0	27.0	15.3	15.3
TUC - 8M	8	8	6.4	6.4	5/8	15.9	22.4	22.4	29.9	29.9	16.2	16.2
TUC - 10M	10	10	7.9	7.9	13/16	20.6	25.9	25.9	33.5	33.5	17.2	17.2
TUC - 12M	12	12	9.5	9.5	13/16	20.6	25.9	25.9	36.0	36.0	22.8	22.8
TUC - 18M	18	18	15.1	15.1	1-1/16	27.0	28.2	28.2	38.3	38.3	24.4	24.4
TUC - 20M	20	20	15.9	15.9	1-3/8	34.9	34.5	34.5	44.6	44.6	26.0	26.0
TUC - 25M	25	25	21.8	21.8	1-3/8	34.9	36.8	36.8	49.1	49.1	31.3	31.3

ALL TUBES (INCH)												
Part Number	A Tube O.D.		D		W Wrench flat		N		E		I	
	in	mm	in	mm	in	mm	in	mm	in	mm	in	mm
TUC - 1	1/16	1.58	0.05	1.27	3/8	9.5	0.55	14	0.70	17.8	0.34	8.6
TUC - 2	1/8	3.17	0.09	2.28	3/8	9.5	0.62	15.74	0.88	22.35	0.50	12.7
TUC - 4	1/4	6.35	0.19	4.82	1/2	12.7	0.77	19.60	1.06	26.92	0.60	15.3
TUC - 5	5/16	7.93	0.25	6.35	5/8	15.9	0.88	22.35	1.17	29.71	0.64	16.2
TUC - 6	3/8	9.52	0.28	7.11	5/8	15.9	0.91	23.11	1.20	30.48	0.66	16.9
TUC - 8	1/2	12.70	0.41	10.41	13/16	20.6	1.02	25.90	1.42	36.07	0.90	22.9
TUC - 12	3/4	19.05	0.62	15.74	1-1/6	27.0	1.17	29.72	1.57	39.88	0.96	24.5
TUC - 16	1	25.40	0.88	22.35	1-3/8	34.9	1.45	36.80	1.93	49.02	1.23	31.2

"D" - Dimension is minimum opening - dimensions are for reference only, and are subject to change without notice.

CAP

TC

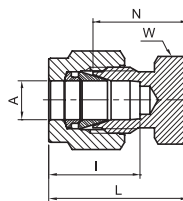

CAPPING END OF TUBE (METRIC)									
Part Number	A Tube O.D.		W Hex. flat		N	L		I	
	mm	mm	mm	mm	mm	mm	mm	mm	mm
TC - 2M	2		12		13.5		20.1		12.9
TC - 3M	3		12		13.5		20.1		12.9
TC - 4M	4		12		14.7		21.3		13.7
TC - 6M	6		14		15.7		23.1		15.3
TC - 8M	8		15		17.0		24.5		16.2
TC - 10M	10		18		19.0		26.6		17.2
TC - 12M	12		22		19.0		29.1		22.8
TC - 15M	15		24		19.8		29.9		24.4
TC - 16M	16		24		19.8		29.9		24.4
TC - 18M	18		27		21.3		31.4		24.4
TC - 20M	20		30		23.9		34.0		26.0
TC - 22M	22		30		23.9		34.0		26.0
TC - 25M	25		35		26.2		38.5		31.3
TC - 28M	28		41		27.7		48.5		36.6
TC - 32M	32		46		32.8		55.8		42.0
TC - 38M	38		55		37.8		65.4		49.4

CAPPING END OF TUBE (INCH)										
Part Number	A Tube O.D.		W Hex. flat		N		L		I	
	in	mm	in	mm	in	mm	in	mm	in	mm
TC - 1	1/16	1.58	5/16	7.9	0.44	11.17	0.59	14.98	0.34	8.6
TC - 2	1/8	3.17	7/16	11.1	0.53	13.46	0.79	20.06	0.5	12.7
TC - 3	3/16	4.76	7/16	11.1	0.58	14.73	0.84	21.84	0.54	13.7
TC - 4	1/4	6.35	1/2	12.7	0.63	16	0.92	23.37	0.6	15.3
TC - 5	5/16	7.93	9/16	14.3	0.67	17.01	0.96	24.38	0.64	16.2
TC - 6	3/8	9.52	5/8	15.9	0.72	18.28	1.01	25.65	0.66	16.9
TC - 8	1/2	12.7	13/16	20.6	0.75	19.05	1.15	29.21	0.9	22.9
TC - 10	5/8	15.87	15/16	23.8	0.78	19.81	1.18	29.97	0.96	24.4
TC - 12	3/4	19.05	1-1/16	27	0.84	21.33	1.24	31.49	0.96	24.5
TC - 14	7/8	22.22	1-3/16	30.2	0.94	23.88	1.34	34.04	1.02	25.9
TC - 16	1	25.4	1-3/8	34.9	1.03	26.16	1.51	38.35	1.23	31.2
TC - 20	1-1/4	31.75	1-3/4	44.5	1.23	31.24	2.1	53.34	1.62	41.2
TC - 24	1-1/2	38.1	2-1/8	54.0	1.47	37.33	2.54	64.52	1.97	50.0
TC - 32	2	50.8	2-3/4	69.9	1.94	49.28	3.41	86.61	2.66	67.6

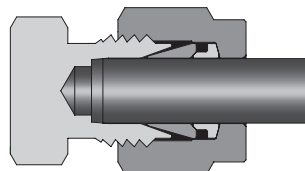

"D" - Dimension is minimum opening - dimensions are for reference only, and are subject to change without notice. For 1/16, 1/8 and 3/16 in 2, 3 and 4mm tube fittings, tighten the nut 3/4 turn.

PLUG

TP

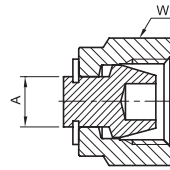

PLUGGING UNUSED PORT OF FITTING (METRIC)			
Part Number	A Tube O.D.		W Hex. flat
	mm		mm
TP - 3M	3		12
TP - 4M	4		12
TP - 6M	6		14
TP - 8M	8		16
TP - 10M	10		19
TP - 12M	12		22
TP - 15M	15		25
TP - 16M	16		25
TP - 18M	18		30
TP - 20M	20		32
TP - 22M	22		32
TP - 25M	25		38
TP - 28M	28		46
TP - 32M	32		50
TP - 38M	38		60
TP - 42M	42		65

PLUGGING UNUSED PORT OF FITTING (INCH)				
Part Number	A Tube O.D.		W Hex. flat	
	in	mm	in	mm
TP - 1	1/16	1.58	5/16	7.9
TP - 2	1/8	3.17	7/16	11.1
TP - 3	3/16	4.76	1/2	12.7
TP - 4	1/4	6.35	9/16	14.3
TP - 5	5/16	7.93	5/8	15.9
TP - 6	3/8	9.52	11/16	17.5
TP - 8	1/2	12.7	7/8	22.2
TP - 10	5/8	15.87	1	25.4
TP - 12	3/4	19.05	1-1/8	28.6
TP - 16	1	25.4	1-1/2	38.1
TP - 20	1-1/4	31.75	1-7/8	47.6
TP - 24	1-1/2	38.1	2-1/4	57.2
TP - 32	2	50.8	3	76.2

PLUG ASSEMBLY INSTRUCTIONS

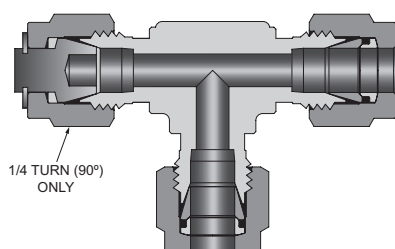

“D” - Dimension is minimum opening - dimensions are for reference only, and are subject to change without notice.
 For 1/16, 1/8 and 3/16 in 2, 3 and 4mm tube fittings, tighten the plug 1/8 turn.
 For over 1 in and over 25mm tube fittings, tighten the plug 1/4 turn.

FEMALE TUBE ADAPTER

TFTA

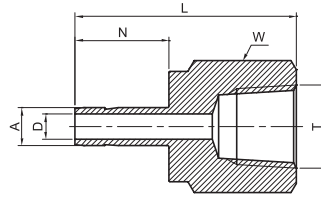

TUBE (METRIC) FEMALE PIPE

Part Number	A Tube O.D.	T NPT	D	W Hex. flat	N	L
	mm	in	mm	mm	mm	mm
TFTA - 3M - 2N	3	1/8	2.1	14	13.5	31.5
TFTA - 3M - 4N	3	1/4	2.1	19	13.5	35.3
TFTA - 4M - 4N	4	1/4	2.2	19	14.2	35.0
TFTA - 6M - 2N	6	1/8	4.0	14	15.7	32.5
TFTA - 6M - 4N	6	1/4	4.0	19	15.7	36.5
TFTA - 6M - 6N	6	3/8	4.0	22	15.7	39.6
TFTA - 6M - 8N	6	1/2	4.0	27	15.7	45.5
TFTA - 8M - 2N	8	1/8	5.6	14	16.9	34.3
TFTA - 8M - 4N	8	1/4	5.6	19	16.9	37.6
TFTA - 8M - 8N	8	1/2	5.6	27	16.9	46.0
TFTA - 10M - 4N	10	1/4	7.1	19	17.6	38.1
TFTA - 10M - 6N	10	3/8	7.1	22	17.6	40.1
TFTA - 10M - 8N	10	1/2	7.7	27	17.6	46.5
TFTA - 12M - 4N	12	1/4	8.8	19	23.3	43.4
TFTA - 12M - 6N	12	3/8	8.8	22	23.3	45.5
TFTA - 12M - 8N	12	1/2	8.8	27	23.3	52.3
TFTA - 16M - 6N	16	3/8	12.7	24	24.7	48.0
TFTA - 16M - 8N	16	1/2	12.7	27	24.7	53.1
TFTA - 20M - 8N	20	1/2	15.1	27	26.6	56.0
TFTA - 20M - 12N	20	3/4	15.1	35	26.6	56.0

"D" - Dimension is minimum opening - dimensions are for reference only, and are subject to change without notice.

FEMALE TUBE ADAPTER

TFTA

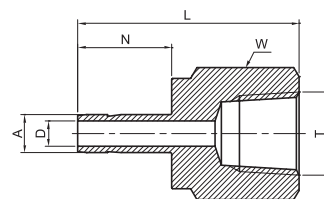

TUBE (INCH) FEMALE PIPE NPT THREAD											
Part Number	A Tube O.D.		T NPT	D		W Hex. flat		N		L	
	in	mm		in	in	mm	in	mm	in	mm	in
TFTA - 2 - 2N	1/8	3.17	1/8	0.08	2.2	9/16	14.3	0.53	13.5	1.24	31.5
TFTA - 2 - 4N	1/8	3.17	1/4	0.08	2.2	3/4	19.1	0.53	13.5	1.39	35.3
TFTA - 3 - 4N	3/16	4.76	1/4	0.12	3.0	3/4	19.1	0.56	14.2	1.41	35.8
TFTA - 4 - 2N	1/4	6.35	1/8	0.17	4.2	9/16	14.3	0.62	15.7	1.30	33.0
TFTA - 4 - 4N	1/4	6.35	1/4	0.17	4.2	3/4	19.1	0.62	15.7	1.46	37.1
TFTA - 4 - 6N	1/4	6.35	3/8	0.17	4.2	7/8	22.2	0.62	15.7	1.55	39.4
TFTA - 4 - 8N	1/4	6.35	1/2	0.17	4.2	1-1/16	27.0	0.62	15.7	1.79	45.5
TFTA - 5 - 4N	5/16	7.93	1/4	0.24	6.0	3/4	19.1	0.67	16.9	1.48	37.6
TFTA - 6 - 2N	3/8	9.52	1/8	0.27	6.85	9/16	14.3	0.69	17.5	1.35	34.3
TFTA - 6 - 4N	3/8	9.52	1/4	0.27	6.85	3/4	19.1	0.69	17.5	1.50	38.1
TFTA - 6 - 6N	3/8	9.52	3/8	0.27	6.85	7/8	22.2	0.69	17.5	1.59	40.4
TFTA - 6 - 8N	3/8	9.52	1/2	0.27	6.85	1-1/16	27.0	0.69	17.5	1.84	46.7
TFTA - 8 - 4N	1/2	12.70	1/4	0.37	9.4	3/4	19.1	0.92	23.3	1.71	43.4
TFTA - 8 - 6N	1/2	12.70	3/8	0.37	9.4	7/8	22.2	0.92	23.3	1.79	45.5
TFTA - 8 - 8N	1/2	12.70	1/2	0.37	9.4	1-1/16	27.0	0.92	23.3	2.04	51.8
TFTA - 10 - 8N	5/8	15.87	1/2	0.50	12.7	1-1/16	27.0	0.97	24.7	2.09	53.1
TFTA - 12 - 8N	3/4	19.05	1/2	0.59	15.0	1-1/16	27.0	0.97	24.7	2.08	52.8
TFTA - 12 - 12N	3/4	19.05	3/4	0.59	15.0	1-5/16	33.3	0.97	24.7	2.16	54.9
TFTA - 12 - 16N	3/4	19.05	1	0.59	15.0	1-5/8	41.3	0.97	24.7	2.30	58.4
TFTA - 16 - 12N	1	25.40	3/4	0.80	20.3	1-5/16	33.3	1.30	33.0	2.39	60.7
TFTA - 16 - 16N	1	25.4	1	0.8	20.3	1-5/8	41.3	1.3	33	2.53	64.3
TFTA - 20 - 20N	1-1/4	31.75	1-1/4	1.02	25.9	2-1/8	54	1.72	43.9	3.06	77.7
TFTA - 24 - 24N	1-1/2	38.1	1-1/2	1.25	31.8	2-3/8	60.3	2.06	52.5	3.5	88.9
TFTA - 32 - 32N	2	50.8	2	1.72	43.7	2-7/8	73.03	2.73	69.4	4.22	107.44

"D" - Dimension is minimum opening - dimensions are for reference only, and are subject to change without notice.

FEMALE TUBE ADAPTER

TFTA

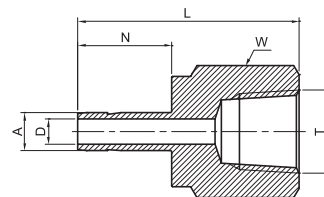

TUBE (INCH) FEMALE PIPE ISO TAPERED THREAD

Part Number	A Tube O.D.		T ISO	D		W Hex. flat		N		L	
	in	mm	in	in	mm	in	mm	in	mm	in	mm
TFTA - 2 - 2P	1/8	3.17	Rc 1/8	0.08	2.2	9/16	14.3	0.53	13.5	1.24	31.5
TFTA - 2 - 4P	1/8	3.17	Rc 1/4	0.08	2.2	3/4	19.1	0.53	13.5	1.39	35.3
TFTA - 3 - 4P	3/16	4.76	Rc 1/4	0.12	3.0	3/4	19.1	0.56	14.2	1.41	35.8
TFTA - 4 - 2P	1/4	6.35	Rc 1/8	0.17	4.2	9/16	14.3	0.62	15.7	1.30	33.0
TFTA - 4 - 4P	1/4	6.35	Rc 1/4	0.17	4.2	3/4	19.1	0.62	15.7	1.46	37.1
TFTA - 4 - 6P	1/4	6.35	Rc 3/8	0.17	4.2	7/8	22.2	0.62	15.7	1.55	39.4
TFTA - 4 - 8P	1/4	6.35	Rc 1/2	0.17	4.2	1-1/16	27.0	0.62	15.7	1.79	45.5
TFTA - 5 - 4P	5/16	7.93	Rc 1/4	0.24	6.0	3/4	19.1	0.67	16.9	1.48	37.6
TFTA - 6 - 2P	3/8	9.52	Rc 1/8	0.27	6.85	9/16	14.3	0.69	17.5	1.35	34.3
TFTA - 6 - 4P	3/8	9.52	Rc 1/4	0.27	6.85	3/4	19.1	0.69	17.5	1.50	38.1
TFTA - 6 - 6P	3/8	9.52	Rc 3/8	0.27	6.85	7/8	22.2	0.69	17.5	1.59	40.4
TFTA - 6 - 8P	3/8	9.52	Rc 1/2	0.27	6.85	1-1/16	27.0	0.69	17.5	1.84	46.7
TFTA - 8 - 4P	1/2	12.70	Rc 1/4	0.37	9.4	3/4	19.1	0.92	23.3	1.71	43.4
TFTA - 8 - 6P	1/2	12.70	Rc 3/8	0.37	9.4	7/8	22.2	0.92	23.3	1.79	45.5
TFTA - 8 - 8P	1/2	12.70	Rc 1/2	0.37	9.4	1-1/16	27.0	0.92	23.3	2.04	51.8
TFTA - 10 - 8P	5/8	15.87	Rc 1/2	0.50	12.7	1-1/16	27.0	0.97	24.7	2.09	53.1
TFTA - 12 - 8P	3/4	19.05	Rc 1/2	0.59	15.0	1-1/16	27.0	0.97	24.7	2.08	52.8
TFTA - 12 - 12P	3/4	19.05	Rc 3/4	0.59	15.0	1-5/16	33.3	0.97	24.7	2.16	54.9
TFTA - 12 - 16P	3/4	19.05	Rc 1	0.59	15.0	1-5/8	41.3	0.97	24.7	2.30	58.4
TFTA - 16 - 12P	1	25.40	Rc 3/4	0.80	20.3	1-5/16	33.3	1.30	33.0	2.39	60.7
TFTA - 16 - 16P	1	25.4	Rc 1	0.8	20.3	1-5/8	41.3	1.3	33.0	2.53	64.3
TFTA - 20 - 20P	1-1/4	31.75	Rc 1-1/4	1.02	25.9	2-1/8	54	1.72	43.9	3.06	77.7
TFTA - 24 - 24P	1-1/2	38.1	Rc 1-1/2	1.25	31.8	2-3/8	60.3	2.06	52.5	3.5	88.9
TFTA - 32 - 32P	2	50.8	Rc 2	1.72	43.7	2-7/8	73.03	2.73	69.4	4.22	107.44

"D" - Dimension is minimum opening - dimensions are for reference only, and are subject to change without notice.

MALE TUBE ADAPTER

TMTA

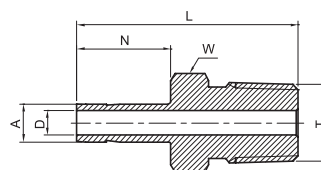

TUBE (METRIC) MALE PIPE NPT THREAD						
Part Number	A Tube O.D.	T NPT	D	W Hex. flat	N	L
	mm	in	mm	mm	mm	mm
TMTA - 3M - 2N	3	1/8	2.1	12	13.5	30.0
TMTA - 3M - 4N	3	1/4	2.1	14	13.5	35.3
TMTA - 6M - 2N	6	1/8	4.0	12	15.7	32.8
TMTA - 6M - 4N	6	1/4	4.0	14	15.7	38.1
TMTA - 6M - 6N	6	3/8	4.0	14	15.7	37.0
TMTA - 6M - 8N	6	1/2	4.0	22	15.7	43.4
TMTA - 8M - 2N	8	1/8	5.6	12	16.9	33.5
TMTA - 8M - 4N	8	1/4	5.6	14	16.9	39.1
TMTA - 8M - 8N	8	1/2	5.6	22	16.9	43.0
TMTA - 10M - 4N	10	1/4	7.1	14	17.6	39.9
TMTA - 10M - 6N	10	3/8	7.7	18	17.6	40.6
TMTA - 10M - 8N	10	1/2	7.7	22	17.6	46.2
TMTA - 12M - 4N	12	1/4	8.8	16	23.3	46.5
TMTA - 12M - 6N	12	3/8	8.8	18	23.3	46.5
TMTA - 12M - 8N	12	1/2	8.8	22	23.3	52.0
TMTA - 16M - 8N	16	1/2	12.7	22	24.7	50.5
TMTA - 20M - 12N	20	3/4	15.1	27	26.6	54.3

"D" - Dimension is minimum opening - dimensions are for reference only, and are subject to change without notice.

MALE TUBE ADAPTER

TMTA

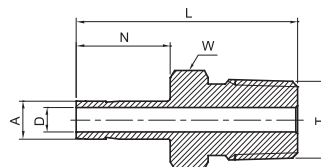

TUBE (INCH) MALE PIPE NPT THREAD											
Part Number	A Tube O.D.		T NPT	D		W Hex. flat		N		L	
	in	mm		in	mm	in	mm	in	mm	in	mm
TMTA - 2 - 2N	1/8	3.17	1/8	0.09	2.2	7/16	11.1	0.53	13.5	1.16	29.5
TMTA - 2 - 4N	1/8	3.17	1/4	0.09	2.2	9/16	14.3	0.53	13.5	1.37	34.8
TMTA - 3 - 2N	3/16	4.76	1/8	0.12	3.0	7/16	11.1	0.56	14.2	1.19	30.2
TMTA - 3 - 4N	3/16	4.76	1/4	0.12	3.0	9/16	14.3	0.56	14.2	1.40	35.6
TMTA - 4 - 2N	1/4	6.35	1/8	0.17	4.2	7/16	11.1	0.62	15.7	1.25	31.8
TMTA - 4 - 4N	1/4	6.35	1/4	0.17	4.2	9/16	14.3	0.62	15.7	1.46	37.1
TMTA - 4 - 6N	1/4	6.35	3/8	0.17	4.2	11/16	17.5	0.62	15.7	1.49	37.9
TMTA - 4 - 8N	1/4	6.35	1/2	0.17	4.2	7/8	22.2	0.62	15.7	1.71	43.4
TMTA - 5 - 2N	5/16	7.93	1/8	0.24	6.0	7/16	11.1	0.67	16.9	1.29	32.7
TMTA - 5 - 4N	5/16	7.93	1/4	0.24	6.0	9/16	14.3	0.67	16.9	1.50	38.1
TMTA - 6 - 2N	3/8	9.52	1/8	0.28	7.1	7/16	11.1	0.69	17.5	1.32	33.5
TMTA - 6 - 4N	3/8	9.52	1/4	0.28	7.1	9/16	14.3	0.69	17.5	1.53	38.9
TMTA - 6 - 6N	3/8	9.52	3/8	0.28	7.1	11/16	17.5	0.69	17.5	1.56	39.6
TMTA - 6 - 8N	3/8	9.52	1/2	0.28	7.1	7/8	22.2	0.69	17.5	1.78	45.2
TMTA - 8 - 4N	1/2	12.70	1/4	0.37	9.4	9/16	14.3	0.92	23.3	1.75	44.5
TMTA - 8 - 6N	1/2	12.70	3/8	0.37	9.4	11/16	17.5	0.92	23.3	1.78	45.2
TMTA - 8 - 8N	1/2	12.70	1/2	0.37	9.4	7/8	22.2	0.92	23.3	20.0	50.8
TMTA - 10 - 6N	5/8	15.87	3/8	0.50	12.7	11/16	17.5	0.97	24.7	1.81	47.6
TMTA - 10 - 8N	5/8	15.87	1/2	0.50	12.7	7/8	22.2	0.97	24.7	2.06	52.3
TMTA - 10 - 12N	5/8	15.87	3/4	0.50	12.7	1-1/16	27.0	0.97	24.7	2.06	52.3
TMTA - 12 - 8N	3/4	19.05	1/2	0.59	15.0	7/8	22.2	0.97	24.7	2.06	52.3
TMTA - 12 - 12N	3/4	19.05	3/4	0.59	15.0	1-1/16	27.0	0.97	24.7	2.06	52.3
TMTA - 12 - 16N	3/4	19.05	1	0.59	15.0	1-3/8	34.9	0.97	24.7	2.28	57.3
TMTA - 14 - 12N	7/8	22.22	3/4	0.60	15.9	1-1/16	27.0	1.05	26.6	2.09	54.3
TMTA - 16 - 12N	1	25.40	3/4	0.80	20.3	1-1/16	27.0	1.30	33.0	2.31	58.7
TMTA - 16 - 16N	1	25.4	1	0.80	20.3	1-3/8	34.9	1.3	33.0	2.6	66.0
TMTA - 20 - 20N	1-1/4	31.75	1-1/4	1.02	25.9	1-3/4	44.5	1.72	43.9	3.16	80.3
TMTA - 24 - 24N	1-1/2	38.1	1-1/2	1.25	31.8	2-1/8	54.0	2.06	52.5	3.72	94.5
TMTA - 32 - 32N	2	50.8	2	1.72	43.7	2-9/16	65.1	2.73	69.4	3.72	119.4

"D" - Dimension is minimum opening - dimensions are for reference only, and are subject to change without notice.

MALE TUBE ADAPTER

TMTA

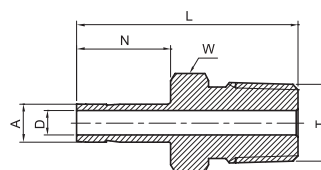

TUBE (INCH) MALE PIPE ISO TAPERED THREAD											
Part Number	A Tube O.D.		T ISO	D		W Hex. flat		N		L	
	in	mm		in	mm	in	mm	in	mm	in	mm
TMTA - 2 - 2P	1/8	3.17	R 1/8	0.09	2.2	7/16	11.1	0.53	13.5	1.16	29.5
TMTA - 2 - 4P	1/8	3.17	R 1/4	0.09	2.2	9/16	14.3	0.53	13.5	1.37	34.8
TMTA - 3 - 2P	3/16	4.76	R 1/8	0.12	3.0	7/16	11.1	0.56	14.2	1.19	30.2
TMTA - 3 - 4P	3/16	4.76	R 1/4	0.12	3.0	9/16	14.3	0.56	14.2	1.40	35.6
TMTA - 4 - 2P	1/4	6.35	R 1/8	0.17	4.2	7/16	11.1	0.62	15.7	1.25	31.8
TMTA - 4 - 4P	1/4	6.35	R 1/4	0.17	4.2	9/16	14.3	0.62	15.7	1.46	37.1
TMTA - 4 - 6P	1/4	6.35	R 3/8	0.17	4.2	11/16	17.5	0.62	15.7	1.49	37.9
TMTA - 4 - 8P	1/4	6.35	R 1/2	0.17	4.2	7/8	22.2	0.62	15.7	1.71	43.4
TMTA - 5 - 2P	5/16	7.93	R 1/8	0.24	6.0	7/16	11.1	0.67	16.9	1.29	32.7
TMTA - 5 - 4P	5/16	7.93	R 1/4	0.24	6.0	9/16	14.3	0.67	16.9	1.50	38.1
TMTA - 6 - 2P	3/8	9.52	R 1/8	0.28	7.1	7/16	11.1	0.69	17.5	1.32	33.5
TMTA - 6 - 4P	3/8	9.52	R 1/4	0.28	7.1	9/16	14.3	0.69	17.5	1.53	38.9
TMTA - 6 - 6P	3/8	9.52	R 3/8	0.28	7.1	11/16	17.5	0.69	17.5	1.56	39.6
TMTA - 6 - 8P	3/8	9.52	R 1/2	0.28	7.1	7/8	22.2	0.69	17.5	1.78	45.2
TMTA - 8 - 4P	1/2	12.70	R 1/4	0.28	7.1	9/16	14.3	0.92	23.3	1.75	44.5
TMTA - 8 - 6P	1/2	12.70	R 3/8	0.39	9.9	11/16	17.5	0.92	23.3	1.78	45.2
TMTA - 8 - 8P	1/2	12.70	R 1/2	0.39	9.9	7/8	22.2	0.92	23.3	2.00	50.8
TMTA - 10 - 6P	5/8	15.87	R 3/8	0.50	12.7	11/16	17.5	0.97	24.7	1.81	47.6
TMTA - 10 - 8P	5/8	15.87	R 1/2	0.50	12.7	7/8	22.2	0.97	24.7	2.06	52.3
TMTA - 10 - 12P	5/8	15.87	R 3/4	0.50	12.7	1-1/16	27.0	0.97	24.7	2.06	52.3
TMTA - 12 - 8P	3/4	19.05	R 1/2	0.59	15.0	7/8	22.2	0.97	24.7	2.06	52.3
TMTA - 12 - 12P	3/4	19.05	R 3/4	0.59	15.0	1-1/16	27.0	0.97	24.7	2.06	52.3
TMTA - 12 - 16P	3/4	19.05	R 1	0.59	15.0	1-3/8	34.9	0.97	24.7	2.28	57.3
TMTA - 14 - 12P	7/8	22.22	R 3/4	0.60	15.9	1-1/16	27.0	1.05	26.6	2.09	54.3
TMTA - 16 - 16P	1	25.4	R 1	0.8	20.3	1-3/8	34.9	1.3	33.0	2.6	66.0
TMTA - 20 - 20P	1-1/4	31.75	R 1-1/4	1.02	25.9	1-3/4	44.5	1.72	43.9	3.16	80.3
TMTA - 24 - 24P	1-1/2	38.1	R 1-1/2	1.25	31.8	2-1/8	54.0	2.06	52.5	3.72	94.5
TMTA - 32 - 32P	2	50.8	R 2	1.72	43.7	2-9/16	65.1	2.73	69.4	3.72	119.4

"D" - Dimension is minimum opening - dimensions are for reference only, and are subject to change without notice.

TUBE FITTINGS |

MALE 90° ELBOW

TME

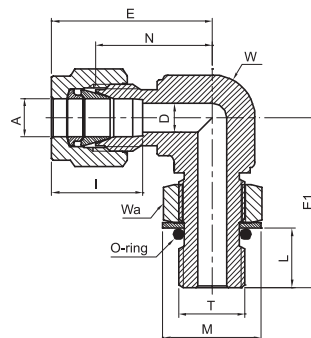
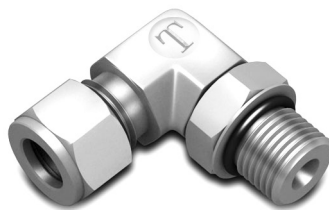

TUBE TO SAE/MS STRAIGHT THREAD BOSS (POSITIONABLE)*																						
Part Number	A Tube O.D.		T SAE/MS	D		W Wrench flat		Wa Hex. flat		N		E		E1		L		M		I		O-ring**
	in	mm	in	in	mm	in	mm	in	mm	in	mm	in	mm	in	mm	in	mm	in	mm	in	mm	Dash no.
TME - 4 - 4ST	1/4	6.35	7/16-20	0.19	4.8	1/2	12.7	9/16	14.3	0.83	21.1	1.12	28.45	1.12	28.45	0.39	9.9	0.65	16.5	0.6	15.3	-904
TME - 4 - 6ST	1/4	6.35	9/16-18	0.19	4.8	5/8	15.9	11/16	17.5	0.91	23.11	1.2	30.48	1.27	32.26	0.44	11.2	0.79	20.1	0.6	15.3	-906
TME - 5 - 5ST	5/16	7.93	1/2-20	0.25	6.35	9/16	14.3	5/8	15.9	0.9	22.86	1.19	30.22	1.16	29.46	0.39	9.9	0.72	18.28	0.64	16.2	-905
TME - 6 - 6ST	3/8	9.52	9/16-18	0.28	7.1	5/8	15.9	11/16	17.5	0.97	24.64	1.26	32.0	1.27	32.26	0.44	11.2	0.79	20.1	0.66	16.9	-906
TME - 6 - 8ST	3/8	9.52	3/4-16	0.28	7.1	13/16	20.6	7/8	22.2	1.07	27.43	1.37	34.8	1.49	37.84	0.5	12.7	1.01	25.65	0.66	16.9	-908
TME - 8 - 8ST	1/2	12.7	3/4-16	0.41	10.41	13/16	20.6	7/8	22.2	1.07	27.43	1.48	37.6	1.49	37.84	0.5	12.7	1.01	25.65	0.9	22.9	-908
TME - 10 - 10ST	5/8	15.87	7/8-14	0.5	12.7	1	25.4	1	25.4	1.16	29.46	1.56	39.62	1.7	43.43	0.56	14.2	1.16	29.46	0.96	24.4	-910
TME - 12 - 12ST	3/4	19.05	1-1/16-12	0.62	15.74	1-1/16	27	1-1/4	31.75	1.22	31.24	1.63	41.4	1.91	48.76	0.65	16.7	1.45	36.6	1.0	24.5	-912
TME - 14 - 14ST	7/8	22.22	1-3/16-12	0.72	18.28	1-1/4	31.75	1-3/8	34.9	1.3	33.02	1.7	43.18	1.99	50.54	0.65	16.7	1.59	40.4	1.02	25.9	-914
TME - 16 - 16ST	1	25.4	1-5/16-12	0.88	22.35	1-3/8	34.9	1-1/2	38.1	1.5	38.35	1.98	50.54	2.1	53.6	0.65	16.7	1.72	43.94	1.22	31.2	-916

TUBE (INCH) TO ISO PARALLEL THREAD (POSITIONABLE)*																						
Part Number	A Tube O.D.		T ISO	D		W Wrench flat		Wa Hex. flat		N		E		E1		L		M		I		O-ring** I.D.
	in	mm	in	in	mm	in	mm	in	mm	in	mm	in	mm	in	mm	in	mm	in	mm	in	mm	Dash no.
TME - 4 - 2PR	1/4	6.35	1/8-28 BSPP	0.1	4.0	1/2	12.7	9/16	14.3	0.77	19.6	1.06	26.9	1.04	26.4	0.32	8.1	0.68	17.3	0.60	15.3	8.0
TME - 4 - 4PR	1/4	6.35	1/4-19 BSPP	0.19	4.8	5/8	15.9	3/4	19.0	0.85	21.6	1.14	28.9	1.27	32.2	0.36	9.1	0.90	22.9	0.60	15.3	-
TME - 6 - 4PR	3/8	9.52	1/4-19 BSPP	0.23	5.9	5/8	15.9	3/4	19.0	0.91	23.1	1.20	30.5	1.27	32.2	0.36	9.1	0.90	22.9	0.66	16.9	-

TUBE (METRIC) TO ISO PARALLEL THREAD (POSITIONABLE)																						
Part Number	A Tube O.D.	T ISO	D	W Wrench flat		Wa Hex. flat		N	E	E1	L	M	I	O-ring** I.D.								
	mm	in	mm	in	mm	in	mm	mm	mm	mm	mm	mm	mm	Dash no.								
TME - 6M - 2PR	6	1/8-28 BSPP	4.0	1/2	12.7	9/16	14.3	19.6	27.0	26.4	8.1	17.3	15.3	8.0								
TME - 8M - 2PR	8	1/8-28 BSPP	4.0	5/8	15.9	9/16	14.3	21.3	28.8	27.4	8.1	17.3	16.2	8.0								
TME - 8M - 4PR	8	1/4-19 BSPP	5.9	5/8	15.9	3/4	19.0	22.4	29.9	32.2	9.1	22.9	16.9	-								

"D" - Dimension is minimum opening - dimensions are for reference only, and are subject to change without notice.

* SAE J 1926 and MS 16142. See page 61 for mounting dimensions.

** O-Rings used are FKM® 90 Durometer. Other O-Ring materials are available on request.

MALE 45° ELBOW

TMHE

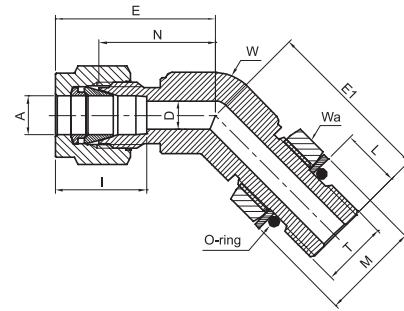

TUBE TO SAE/MS STRAIGHT THREAD BOSS (POSITIONABLE)*																						
Part Number	A Tube O.D.		T SAE/MS	D		W Wrench flat		Wa Hex. flat		N		E		E1		L		M		I		O-ring**
	in	mm	in	in	mm	in	mm	in	mm	in	mm	in	mm	in	mm	in	mm	in	mm	in	mm	Dash no.
TMHE - 4 - 4ST	1/4	6.35	7/16-20	0.19	4.8	1/2	12.7	9/16	14.3	0.72	18.29	1.01	25.65	1.01	25.65	0.39	9.9	0.65	16.5	0.6	15.3	-904
TMHE - 6 - 6ST	3/8	9.52	9/16-18	0.28	7.1	5/8	15.9	11/16	17.5	0.81	20.06	1.1	28.0	1.06	28.2	0.44	11.2	0.79	20.1	0.66	16.9	-906
TMHE - 8 - 8ST	1/2	12.7	3/4-16	0.41	10.41	13/16	20.6	7/8	22.2	0.86	21.84	1.26	32.0	1.27	32.25	0.5	12.7	1.01	25.65	0.9	22.9	-908
TMHE - 12 - 12ST	3/4	19.05	1-1/16-12	0.62	15.74	1-1/16	27.0	1-1/4	31.75	1.17	29.7	1.57	39.87	1.86	47.24	0.65	16.7	1.45	36.6	0.96	24.4	-910
TMHE - 16 - 16ST	1	25.4	1-5/16-12	0.88	22.35	1-3/8	34.9	1-1/2	38.1	1.39	35.3	1.87	47.5	1.97	50.24	0.65	16.7	1.72	43.94	1.0	24.5	-912

TUBE (INCH) TO ISO PARALLEL THREAD (POSITIONABLE)*																						
Part Number	A Tube O.D.		T ISO	D		W Wrench flat		Wa Hex. flat		N		E		E1		L		M		I		O-ring** I.D.
	in	mm	in	in	mm	in	mm	in	mm	in	mm	in	mm	in	mm	in	mm	in	mm	in	mm	Dash no.
TMHE - 4 - 2PR	1/4	6.35	1/8-28 BSPP	0.16	4.0	9/16	14.3	9/16	14.3	0.69	17.5	0.98	24.9	0.94	24.0	0.32	8.1	0.68	17.3	0.60	15.3	8.0

TUBE (METRIC) TO ISO PARALLEL THREAD (POSITIONABLE)																						
Part Number	A Tube O.D.		T ISO	D		W Wrench flat		Wa Hex. flat		N		E		E1		L		M		I		O-ring** I.D.
	mm	in	in	mm	in	mm	in	mm	in	mm	mm	mm	mm	mm	mm	mm	mm	mm	mm	mm	mm	Dash no.
TMHE - 6 - 2PR	6	1/8-28 BSPP	4.0	9/16	14.3	9/16	14.3	17.55	24.9	24.0	8.1	17.3	15.3	8.0								

"D" - Dimension is minimum opening - dimensions are for reference only, and are subject to change without notice.

* ISO PARALLEL THREAD FOR BS-2779. See page 64 for mounting dimensions.

** O-Rings used are Vitor® 90 Durometer. Other O-Ring materials are available on request.

MALE RUN TEE

TMRT

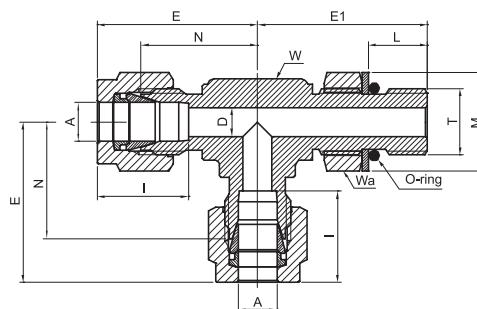
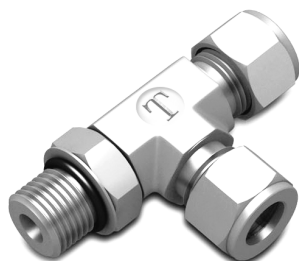

TUBE TO SAE/MS STRAIGHT THREAD BOSS (POSITIONABLE)*

Part Number	A Tube O.D.		T SEA/MS	D		W Wrench flat		Wa Hex. flat		N		E		E1		L		M		I		O-ring**
	in	mm	in	in	mm	in	mm	in	mm	in	mm	in	mm	in	mm	in	mm	in	mm	in	mm	Dash no.
TMRT - 4 - 4ST	1/4	6.35	7/16-20	0.19	4.8	1/2	12.7	9/16	14.3	0.83	21.1	1.12	28.45	1.12	28.45	0.39	9.9	0.65	16.5	0.60	15.3	-904
TMRT - 6 - 6ST	3/8	9.52	9/16-18	0.28	7.1	5/8	15.9	11/16	17.5	0.97	24.64	1.26	32	1.27	32.26	0.44	11.2	0.79	20.1	0.66	16.9	-906
TMRT - 8 - 8ST	1/2	12.7	3/4-16	0.41	10.41	13/16	20.6	7/8	22.2	1.07	27.43	1.48	37.6	1.49	37.84	0.5	12.7	1.01	25.65	0.9	22.9	-908
TMRT - 12 - 12ST	3/4	19.05	1-1/16-12	0.62	15.74	1-1/16	27	1-1/4	31.75	1.22	31.24	1.63	41.4	1.91	48.76	0.65	16.7	1.45	36.6	1.0	24.5	-912
TMRT - 16 - 16ST	1	25.4	1-5/16-12	0.88	22.35	1-3/8	34.9	1-1/2	38.1	1.5	38.35	1.98	50.54	2.1	53.6	0.65	16.7	1.72	43.94	1.22	31.2	-916

TUBE (INCH) TO ISO PARALLEL THREAD (POSITIONABLE)*

Part Number	A Tube O.D.		T ISO	D		W Wrench flat		Wa Hex. flat		N		E		E1		L		M		I		O-ring** I.D.
	in	mm	in	in	mm	in	mm	in	mm	in	mm	in	mm	in	mm	in	mm	in	mm	in	mm	Dash no.
TMRT - 4 - 2PR	1/4	6.35	1/8-28 BSPP	0.16	4.0	1/2	12.7	9/16	14.3	0.77	19.6	1.06	26.9	1.04	26.4	0.32	8.1	0.68	17.3	0.60	15.3	8.0
TMRT - 4 - 4PR	1/4	6.35	1/4-19 BSPP	0.19	4.8	5/8	15.9	3/4	19.0	0.85	21.6	1.14	28.9	1.27	32.2	0.36	9.1	0.90	22.9	0.60	15.3	-
TMRT - 6 - 4PR	3/8	9.53	1/4-19 BSPP	0.23	5.9	5/8	15.9	3/4	19.0	0.91	23.1	1.20	30.5	1.27	32.2	0.36	9.1	0.90	22.9	0.66	16.9	-

TUBE (METRIC) TO ISO PARALLEL THREAD (POSITIONABLE)

Part Number	A Tube O.D.		T ISO	D		W Wrench flat		Wa Hex. flat		N	E	E1	L	M	I	O-ring** I.D.
	mm	in	in	mm	in	mm	in	mm	mm	mm	mm	mm	mm	mm	mm	Dash no.
TMRT - 8M - 4PR	8	1/4-19 BSPP	5.9	5/8	15.9	3/4	19.0	22.4	29.9	32.2	9.1	22.9	16.9	-		

MALE BRANCH TEE

TMBT

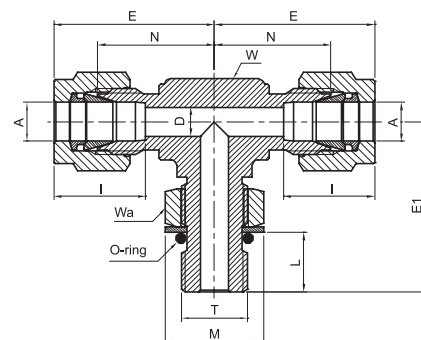

TUBE TO SAE/MS STRAIGHT THREAD BOSS (POSITIONABLE) *																						
Part Number	A Tube O.D.		T SEA/MS	D		W Wrench flat		Wa Hex. flat		N		E		E1		L		M		I		O-ring**
	in	mm	in	in	mm	in	mm	in	mm	in	mm	in	mm	in	mm	in	mm	in	mm	in	mm	Dash no.
TMBT - 4 - 4ST	1/4	6.35	7/16-20	0.19	4.8	1/2	12.7	9/16	14.3	0.83	21.1	1.12	28.45	1.12	28.45	0.39	9.9	0.65	16.5	0.60	15.3	-904
TMBT - 6 - 6ST	3/8	9.52	9/16-18	0.28	7.1	5/8	15.9	11/16	17.5	0.97	24.64	1.26	32	1.27	32.26	0.44	11.2	0.79	20.1	0.66	16.9	-906
TMBT - 8 - 8ST	1/2	12.7	3/4-16	0.41	10.41	13/16	20.6	7/8	22.2	1.07	27.43	1.48	37.6	1.49	37.84	0.5	12.7	1.01	25.65	0.9	22.9	-908
TMBT - 12 - 12ST	3/4	19.05	1-1/16-12	0.62	15.74	1-1/16	27.0	1-1/4	31.75	1.22	31.24	1.63	41.4	1.91	48.76	0.65	16.7	1.45	36.6	1.0	24.5	-912
TMBT - 16 - 16ST	1	25.4	1-5/16-12	0.88	22.35	1-3/8	34.9	1-1/2	38.1	1.5	38.35	1.98	50.54	2.1	53.6	0.65	16.7	1.72	43.94	1.22	31.2	-916
TMBT - 6 - 6ST	3/8	9.52	9/16-18	0.28	7.1	5/8	15.9	11/16	17.5	0.97	24.64	1.26	32.0	1.27	32.26	0.44	11.2	0.79	20.1	0.66	16.9	-906

TUBE (INCH) TO ISO PARALLEL THREAD (POSITIONABLE)*																						
Part Number	A Tube O.D.		T ISO	D		W Wrench flat		Wa Hex. flat		N		E		E1		L		M		I		O-ring** I.D.
	in	mm	in	in	mm	in	mm	in	mm	in	mm	in	mm	in	mm	in	mm	in	mm	in	mm	Dash no.
TMBT - 4 - 2PR	1/4	6.35	1/8-28 BSPP	0.16	4.0	1/2	12.7	9/16	14.3	0.77	19.6	1.06	26.9	1.04	26.4	0.32	8.1	0.68	17.3	0.60	15.3	8.0

TUBE (METRIC) TO ISO PARALLEL THREAD (POSITIONABLE)																						
Part Number	A Tube O.D.		T ISO	D		W Wrench flat		Wa Hex. flat		N		E		E1		L		M		I		O-ring** I.D.
	mm	mm	in	mm	mm	in	mm	in	mm	mm	mm	mm	mm	mm	mm	mm	mm	mm	mm	mm	mm	Dash no.
TMBT - 6M - 2PR	6	6	1/8-28 BSPP	4.0	4.0	1/2	12.7	9/16	14.3	19.6	19.6	27.0	27.0	26.4	26.4	8.1	8.1	17.3	17.3	15.3	15.3	8.0

"D" - Dimension is minimum opening - dimensions are for reference only, and are subject to change without notice.

* SAE J 1926 and MS 16142. See page 61 for mounting dimensions.

** O-Rings used are Vitor® 90 Durometer. Other O-Ring materials are available on request.

MOUNTING DIMENSIONS

FOR SAE J1926 & MS 16142 BOSS

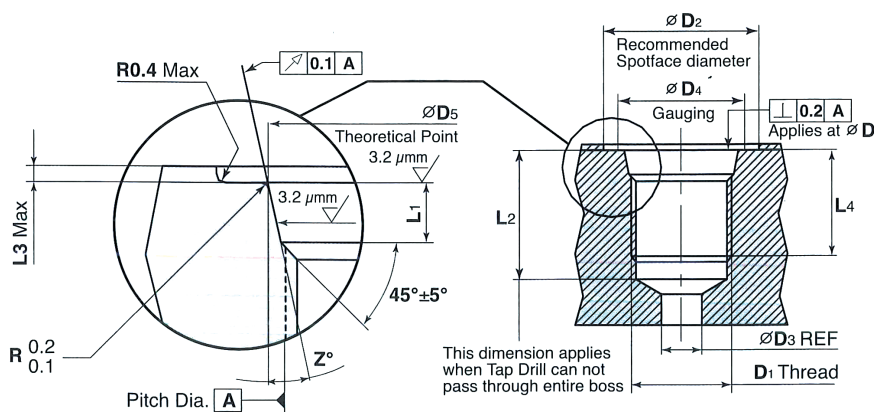

MOUNTING DIMENSIONS FOR O-SEAL CONNECTORS (SAE/MS)											
TUBE O.D.		D1 Thread Size	D2 Min. diameter	D3 Min. diameter	D4 Min	D5 ± 0.05	L1 ± 0.02	L2 Min	L3 Max.	L4 Min. full Thread	Z° ± 1°
in	mm	in	± 0.05	mm	mm	mm	mm	mm	mm	mm	mm
1/8	3.18	5/16 - 24 UNF - 2B	17	1.6	11	9.15	2.1	12	1.6	10	12
3/16	4.76	3/8 - 24 UNF - 2B	19	3.5	13	10.75	2.1	12	1.6	10	12
1/4	6.35	7/16 - 20 UNF - 2B	21	4.5	15	12.45	2.6	14	1.6	11.5	12
5/16	7.94	1/2 - 20 UNF - 2B	23	6	16	14.05	2.6	14	1.6	11.5	12
3/8	9.52	9/16 - 18 UNF - 2B	25	7.5	18	15.70	2.7	15.5	1.6	12.7	12
1/2	12.70	3/4 - 16 UNF - 2B	30	10	22	20.65	2.7	17.5	2.4	14.3	15
5/8	15.88	7/8 - 14 UNF - 2B	34	12.5	26	24	2.7	20	2.4	16.7	15
3/4	19.05	1 1/16 - 12 UNF - 2B	41	16	32	29.2	3.5	23	2.4	19	15
7/8	22.22	1 3/16 - 12 UN - 2B	45	18	35	32.4	3.5	23	2.4	19	15
1	25.40	1 5/16 - 12 UN - 2B	49	21	38	35.55	3.5	23	3.2	19	15

"D" - Dimension is minimum opening - dimensions are for reference only, and are subject to change without notice.

INSTALLATION INSTRUCTIONS :

Figure 1

Locking backed off

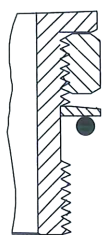

Lubricate the O-ring by inserting it into the groove adjacent to the face of the metal back-up washer which is assembled at the extreme end of the groove as shown in Figure 1.

Figure 2

Fitting install hand tight

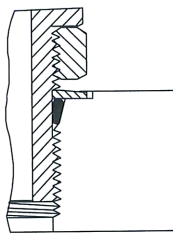

Install the fitting into the SAE straight thread boss, figure 2, until the metal back-up washer contacts the face of the boss as shown in Figure 2.

Figure 3

Fittings backed-off for alignment (1 turn maximum)

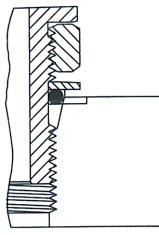

Position the fitting by turning it counter clockwise up to a maximum of one turn. (See Figure 3.)

Figure 4

Fitting locknut tight to appropriate torque

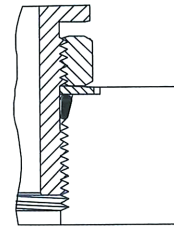

Holding the pad of the fitting with a wrench, tighten the locknut and washer against the face as shown in Figure 4.

ISO PARALLEL THREAD FOR BS-2779

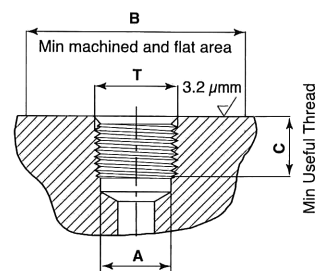

MOUNTING DIMENSIONS OF CONNECTORS								
T Female	A Thread Minor Diameter				D4 Min Machine and Flat Area		C Min useful Thread	
	max		min		mm	mm	mm	mm
	in	mm	in	mm				
1/8 - 28	0.35	8.89	0.34	8.64	0.5	13.50	0.28	7.00

INSTALLATION INSTRUCTIONS :

Figure 1

Locking backed off

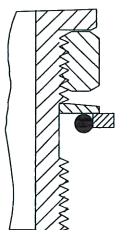

Lubricate the O-ring by inserting it into the groove adjacent to the face of the metal back-up washer which is assembled at the extreme end of the groove as shown in Figure 1.

Figure 2

Fitting install hand tight

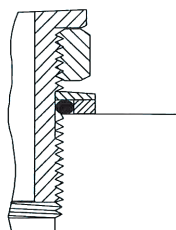

Install the fitting into the SAE straight thread boss until the metal back-up washer contacts the face of the boss as shown in Figure 2.

Figure 3

Fittings backed-off for alignment (1 turn maximum)

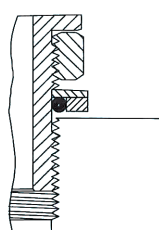

Position the fitting by turning it counter clock wise up to a maximum of one turn. See Figure 3.

Figure 4

Fitting locknut tight to appropriate torque

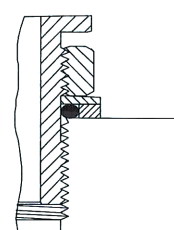

Holding the pad of the fitting with a wrench, tighten the lock-nut and washer against the face as shown in Figure 4.

"D" - Dimension is minimum opening - dimensions are for reference only, and are subject to change without notice.

BACK FERRULE

TBF

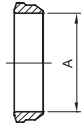

METRIC	
Part Number	A Tube O.D.
	mm
TBF - 2M	2
TBF - 3M	3
TBF - 4M	4
TBF - 6M	6
TBF - 8M	8
TBF - 10M	10
TBF - 12M	12
TBF - 14M	14
TBF - 15M	15
TBF - 16M	16
TBF - 18M	18
TBF - 20M	20
TBF - 25M	25
TBF - 28M	28
TBF - 32M	32
TBF - 38M	38
TBF - 42M	42

INCH		
Part Number	A Tube O.D.	
	in	mm
TBF - 1	1/16	1.58
TBF - 2	1/8	3.17
TBF - 3	3/16	4.76
TBF - 4	1/4	6.35
TBF - 5	5/16	7.93
TBF - 6	3/8	9.52
TBF - 8	1/2	12.70
TBF - 10	5/8	15.87
TBF - 12	3/4	19.05
TBF - 14	7/8	22.22
TBF - 16	1	25.40
TBF - 20	1-1/4	31.75
TBF - 24	1-1/2	38.10
TBF - 32	2	50.80

FRONT FERRULE

TFF

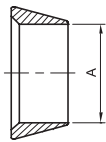

METRIC		INCH		
Part Number	A Tube O.D.	Part Number	A Tube O.D.	
	mm		in	mm
TFF - 2M	2	TFF - 1	1/16	1.58
TFF - 3M	3	TFF - 2	1/8	3.17
TFF - 4M	4	TFF - 3	3/16	4.76
TFF - 6M	6	TFF - 4	1/4	6.35
TFF - 8M	8	TFF - 5	5/16	7.93
TFF - 10M	10	TFF - 6	3/8	9.52
TFF - 12M	12	TFF - 8	1/2	12.70
TFF - 14M	14	TFF - 10	5/8	15.87
TFF - 15M	15	TFF - 12	3/4	19.05
TFF - 16M	16	TFF - 14	7/8	22.22
TFF - 18M	18	TFF - 16	1	25.40
TFF - 20M	20	TFF - 20	1-1/4	31.75
TFF - 22M	22	TFF - 24	1-1/2	38.10
TFF - 25M	25	TFF - 32	2	50.80
TFF - 28M	28			
TFF - 32M	32			
TFF - 38M	38			
TFF - 42M	42			

FERRULE SET

TFS



METRIC		INCH		
Part Number	Tube O.D.	Part Number	Tube O.D.	
	mm		in	mm
TFS - 2M	2	TFS - 1	1/16	1.58
TFS - 3M	3	TFS - 2	1/8	3.17
TFS - 4M	4	TFS - 3	3/16	4.76
TFS - 6M	6	TFS - 4	1/4	6.35
TFS - 8M	8	TFS - 5	5/16	7.93
TFS - 10M	10	TFS - 6	3/8	9.52
TFS - 12M	12	TFS - 8	1/2	12.7
TFS - 14M	14	TFS - 10	5/8	15.87
TFS - 15M	15	TFS - 12	3/4	19.05
TFS - 16M	16	TFS - 14	7/8	22.22
TFS - 18M	18	TFS - 16	1	25.40
TFS - 20M	20	TFS - 20	1-1/4	31.75
TFS - 22M	22	TFS - 24	1-1/2	38.10
TFS - 25M	25	TFS - 32	2	50.80
TFS - 28M	28			
TFS - 32M	32			
TFS - 38M	38			
TFS - 42M	42			

* The ferrule set contains one front ferrule and back ferrule. Please order ferrule sets in multiples of ten.

"D" - Dimension is minimum opening - dimensions are for reference only, and are subject to change without notice.

NUT

TFN

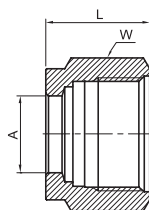

METRIC			
Part Number	A Tube O.D.	W Hex. Flat	L
	mm	mm	mm
TFN - 2M	2	12	11.9
TFN - 3M	3	12	11.9
TFN - 4M	4	12	11.9
TFN - 6M	6	14	12.7
TFN - 8M	8	16	13.5
TFN - 10M	10	19	15.1
TFN - 12M	12	22	17.4
TFN - 14M	14	25	17.4
TFN - 15M	15	25	17.4
TFN - 16M	16	25	17.4
TFN - 18M	18	30	17.4
TFN - 20M	20	32	17.4
TFN - 22M	22	32	17.4
TFN - 25M	25	38	20.6
TFF - 28M	28	46	30.6
TFF - 32M	32	50	34.4
TFF - 38M	38	60	40.6
TFF - 42M	42	65	44.7

INCH						
Part Number	A Tube O.D.		W Hex. Flat		L	
	in	mm	in	mm	in	mm
TFN - 1	1/16	1.58	5/16	7.9	0.31	7.87
TFN - 2	1/8	3.17	7/16	11.1	0.47	11.93
TFN - 3	3/16	4.76	1/2	12.7	0.47	11.93
TFN - 4	1/4	6.35	9/16	14.3	0.50	12.70
TFN - 5	5/16	7.93	5/8	15.9	0.53	13.46
TFN - 6	3/8	9.52	11/16	17.5	0.56	14.20
TFN - 8	1/2	12.70	7/8	22.2	0.69	17.50
TFN - 10	5/8	15.87	1	25.4	0.69	17.52
TFN - 12	3/4	19.05	1-1/8	28.6	0.69	17.50
TFN - 14	7/8	22.22	1-1/4	31.8	0.69	17.52
TFN - 16	1	25.4	1-1/2	38.1	0.81	20.57
TFN - 20	1-1/4	31.75	1-7/8	47.6	1.25	31.75
TFN - 24	1-1/2	38.1	2-1/4	57.2	1.50	38.10
TFN - 32	2	50.8	3	76.2	2.06	52.32

NUT-FERRULE SET

TNFS



METRIC	
Part Number	Tube O.D.
	mm
TNFS - 2M	2
TNFS - 3M	3
TNFS - 4M	4
TNFS - 6M	6
TNFS - 8M	8
TNFS - 10M	10
TNFS - 12M	12
TNFS - 14M	14
TNFS - 15M	15
TNFS - 16M	16
TNFS - 18M	18
TNFS - 20M	20
TNFS - 22M	22
TNFS - 25M	25
TNFS - 28M	28
TNFS - 32M	32
TNFS - 38M	38
TNFS - 42M	42

INCH		
Part Number	Tube O.D.	
	in	mm
TNFS - 1	1/16	1.58
TNFS - 2	1/8	3.17
TNFS - 3	3/16	4.76
TNFS - 4	1/4	6.35
TNFS - 5	5/16	7.93
TNFS - 6	3/8	9.52
TNFS - 8	1/2	12.7
TNFS - 10	5/8	15.87
TNFS - 12	3/4	19.05
TNFS - 14	7/8	22.22
TNFS - 16	1	25.4
TNFS - 20	1-1/4	31.75
TNFS - 24	1-1/2	38.10
TNFS - 32	2	50.80

* Please order Nut-Ferrule Sets in multiples of five.

MALE NUT (INCH)

TMN

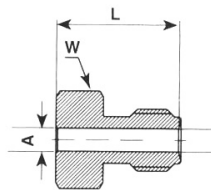

Part Number	A Tube O.D.		W Hex. flat		L	
	in	mm	in	mm	in	mm
TMN - 1	1/16	1.58	1/4	6.4	3/8	9.52

TUBE INSERT

TTI

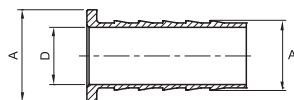

Part Number	METRIC		
	A Tube O.D.	A1 Tube O.D.	D
	mm	mm	mm
TTI - 6M - 4M	6	4	2.8
TTI - 8M - 6M	8	6	4.4
TTI - 10M - 8M	10	8	6.4
TTI - 12M - 8M	12	8	6.4
TTI - 12M - 10M	12	10	8.3

Part Number	INCH					
	A Tube O.D.		A1 Tube O.D.		D	
	in	mm	in	mm	in	mm
TTI - 3 - 2	3/16	4.76	1/8	3.17	0.09	2.30
TTI - 4 - 2	1/4	6.35	1/8	3.17	0.09	2.30
TTI - 4 / 70	1/4	6.35	.17	4.32	0.11	2.70
TTI - 4 - 3	1/4	6.35	3/16	4.76	0.12	3.10
TTI - 5 - 2	5/16	7.93	1/8	3.17	0.09	2.30
TTI - 5 - 3	5/16	7.93	3/16	4.76	0.12	3.00
TTI - 5 - 4	5/16	7.93	1/4	6.35	0.18	4.65
TTI - 6 - 3	3/8	9.52	3/16	4.76	0.12	3.10
TTI - 6 - 4	3/8	9.52	1/4	6.35	0.18	4.65
TTI - 8 - 4	1/2	12.70	1/4	6.35	0.18	4.65
TTI - 8 - 6	1/2	12.70	3/8	9.52	0.31	7.80
TTI - 10 - 6	5/8	15.87	3/8	9.52	0.31	7.80
TTI - 10 - 8	5/8	15.87	1/2	12.70	0.44	11.10
TTI - 12 - 8	3/4	19.05	1/2	12.70	0.44	11.10
TTI - 12 - 10	3/4	19.05	5/8	15.87	0.56	14.20
TTI - 16 - 12	1	25.40	3/4	19.05	0.69	17.50

"D" - Dimension is minimum opening - dimensions are for reference only, and are subject to change without notice.